

Parts (Test) Certificate GB-1461 Revision 13

| | |
|--------------------------------------|--|
| Issued by | NMO |
| In accordance with | The applicable requirements of EN45501:2015 and Welmec guides 2.1, 2.3 and 8.8 |
| Applicant | Dini Argeo S.r.l. Via della Fisica 20 41042 Spezzano di Fiorano Modena Italy |
| In respect of | The model of an Indicating Device tested as a separate part of a weighing instrument. Manufacturer: The applicant Type: 3590E, CPWE, DFW and DGT Series |
| Characteristics | Characteristics are provided in the Descriptive Annex of this Parts (test) certificate. |
| Description and documentation | The indicating device is described in the Descriptive Annex. Documents appertaining to this test certificate are held by NMO. |
| Remarks | The conformity was established by testing and examinations described in the Appendix to the Descriptive Annex and the associated Evaluation Report P02218. This revision replaces previous versions of the certificate. |

Issue Date: 13 July 2018



Grégory Glas
Lead Technical Manager
For and on behalf of the Head of Technical Services

Descriptive Annex

1 INTRODUCTION

The indicating devices which are certified as weight indicators designed to be connected to a load receptor to form a Class III and IIII, Non-Automatic Weighing Instrument. These instruments may be fitted with a built-in printer and WiFi connectivity (optional). These instruments can be configured with single-interval, multi-interval, or multi-range weighing options, an external AC mains adapter, and an internal rechargeable battery.

The indicators are not designed for direct sales to the public.

2 FUNCTIONAL DESCRIPTION

2.1 Construction

The indicator construction is dependent on the model number; the designation follows the following format: "Family"+"suffix":

Family: 3590E, CPWE, DFW, DGT series

Suffix: being alphanumeric characters used to indentify different variants.

The variants include various keypads (5 to 20 keys), functional waterproof keypad, number of weighing channels, ABS, painted steel or stainless steel case in different sizes (see figures from 1 on for different mounting cases), communication ports, devices (see section 2.2 for permitted devices) and permitted interfaces (see section 4.1 for permitted interfaces).

2.2 Devices

The Dini Argeo family of indicators may have the following devices:

- Semi-automatic zero setting ($\leq 4\%$ Max)
- Zero tracking ($\leq 4\%$ Max)
- Semi-automatic subtractive tare weighing
- Pre-set tare
- Recall of Gross indication when tare is active
- Determination of stability of equilibrium
- Indication of stability of equilibrium
- Multi-range and multi-interval function
- Checking of display
- Printing
- Alibi storage device
- Gravity compensation
- Checkweighing
- Real time clock
- Counting
- Command via external device (PC)
- Accumulation
- Battery level indicator
- Remote control
- LCD or LED
- Peak Hold
- Gross, Net, Tare, Preset tare, Print, Zero, Motion, Accumulation, Over/Under weight and Network indicators

2.3 Functions

2.3.1 Power up

At switch on, the system goes through a standard check, making any defect obvious.

2.3.2 Display

The indicator shall be configured to display a weight up to a value not exceeding Max + 9 e. Any weight above or below gross zero will result in "OUT CAPACITY" being displayed.

2.3.3 Semi-automatic zero setting device

The "ZERO" key on the keypad sets zero. A successful zero can only be set if the weight value is stable. A zero weight is then displayed and the zero indicator is illuminated.

The zero-setting range must be set to 4 % of maximum capacity or less.

2.3.4 Zero tracking device

Zero tracking operates when the indication is at zero, or at a negative Net value equivalent to Gross zero, when the weight display is stable. The range of zero-setting must be set to 4 % of maximum capacity or less, and can be disabled by the user.

2.3.5 Semi-automatic tare weighing device

The Tare key on the keypad initiates the semi-automatic subtractive tare device. The indicator displays the net weight with a "Net" indication. The SELECT key can be used to toggle between Net, Gross and Tare weight values.

2.3.6 Stability of equilibrium

The "Err Mot" indicator is ON and all devices are inhibited when the weight is unstable.

2.3.7 Printing / Alibi storage

The indicator must be configured to ensure that printed and stored data meet the following requirements:

- Gross weights may be printed/stored without designation, or if designated, identified by Gross, G or B
- If only Net values are printed/stored they may be printed/stored without designation, or if designated, identified by Net or N
- If Net weights are printed/stored with corresponding Gross and/or Tare weights, the Net and Tare values must be identified
- If different tare devices are in operation, each tare value should be clearly identified
- Preset tare values shall be identified as Preset Tare or PT
- The unit associated to each value shall be printed/stored
- All weight values shall be rounded to the scale interval, and not have more than one non-significant zero
- All other values (weight values and non-weight values) should be clearly and unambiguously identified
- A unique identification number shall identify each record

2.3.8 Specific modes of operation

The Dini Argeo family of indicators may be configured to operate in the following modes in addition to the standard weighing mode. Each mode shall be clearly identified, and it shall be possible to switch back to the weighing mode at all times.

3590E and CPWE Series – See the related user manuals

- Version for totalization and simple dosages
- Version for quantity (pieces, litres, etc.) Counting systems
- Version for vehicle weighing systems with input/output function
- Version for statistical check of pre-packaged goods
- Version for industrial price computing
- Version for wheel and axle weighing*
- Version for static axle weighing with input/output function*
- Multi-component dosage systems**
- Single product dosage systems, in loading or unloading**
- Management of continuous dosages on belt**
- Static or dynamic weight control on belt**
- Continuous dosage in unloading with flow adjustment
- Indicator, repeater, transmitter of weight
- Connection to up to 4 load receptors via the 4 channels converter

DFW Series – See the related user manuals

- Indicator, repeater, transmitter of weight
- Wheel / axle weighing*

DGT Series – See the related user manuals

- Indicator, repeater, transmitter of weight
- Indicators for bench or panel applications

* use of individual wheel and/or axle loads for Article 1.2(a) purposes may be prohibited in some Member States.

** some of these functions may fall outside of the scope of Directive 2014/31/EU.

3 TECHNICAL CHARACTERISTICS

3.1 Technical data

| | |
|---|--|
| Power supply | 3590E Series: 6-12 V DC External/Internal 110-240 V AC 50/60 Hz |
| | CPWE Series: 8-36 V DC |
| | DGT Series:12-24 V DC External/Internal 110-240 V AC 50/60 Hz |
| | DFW Series:12 V DC External/Internal 110-240 V AC 50/60 Hz |
| Maximum number of scale intervals | 10 000 |
| Load cell excitation voltage | 5 V DC |
| Minimum load cell impedance | 20 Ω |
| Maximum load cell impedance | 3 k Ω |
| Minimum input voltage per verification scale interval | 0.3 μ V/div |
| Measuring range minimum voltage | 0.3 mV |
| Measuring range maximum voltage | 30 mV |

| | |
|--|--|
| Fraction of maximum permissible error | $P_{ind} = 0.5$ ($P_{ind} = 0$ for digital load cells) ($P_{ind} = 0$ for analogue load cells with junction box) |
| Operating temperature range | -10 / + 40 °C |
| Load cell connection | 4 or 6 wire |
| Maximum Load cell cable length (junction box to indicator) | 200 m/mm ² |

3.2 Documentation and drawings

The instrument is fully described in technical file reference held at NMO.

| Reference № | Drawing description |
|-------------|--|
| P1220-XXX | Drawings about ABS case for 3590EXP / DFWK06XP / DFWRXP series |
| P1390-XXX | Drawings about Stainless steel case for DFWLI,DFWLKI,DFWLID |
| P1249-XXX | Drawings about ABS case for DFWL |
| P1372-XXX | Drawings about Stainless steel case for 3590EGT / 3590EXT |

4 PERIPHERAL DEVICES AND INTERFACES

4.1 Interfaces

The instrument may have the following protected interfaces:

- 4 or 6 wire load cell connection
- DC voltage input
- RS-232
- RS-485
- Control inputs/outputs
- USB
- Ethernet
- Bluetooth
- Optoisolated inputs
- Photomosfet outputs
- SENSOR (Digital in)
- RF (radio frequency)
- WiFi
- Analogue ouput and input
- Profibus
- Profinet
- DeviceNet
- CANopen
- Ethercat

4.2 Peripheral devices

The instrument may be connected to any peripheral device that has been issued with a Parts (Test) Certificate by a Notified Body responsible for type examination under Directive 2014/31/EU in any Member State and bears the CE marking of conformity to the relevant directives; or

A peripheral device without a Parts (Test) certificate may be connected under the following conditions:

- it bears the CE marking for conformity to the EMC Directive;
- it is not capable of transmitting any data or instruction into the weighing instrument, other than to release a printout, checking for correct data transmission or validation;
- it prints weighing results and other data as received from the weighing instrument without any modification or further processing; and
- it complies with the applicable requirements of EN:45501, i.e. 4.2, 4.4, 4.6 and 4.7.

A printing device may print additional information such as date or number to identify the printed weighing result(s) or sets of weighing results.

5 SOFTWARE

5.1 Security

The software is held on the Flash Memory and cannot be modified by the user. The calibration and legally relevant parameters are protected via physical or software means.

A jumper located on the main board prevents all access to the legally relevant parameters.

Alternatively, software sealing may be used to protect the calibration and legally relevant parameters. Two non-editable counters, designated CAL and CONFIG, are incremented each time the calibration and legally relevant parameters respectively are modified, with access to these parameters being password-protected. The counters' values and designations must be written on a tamper-evident label on or near the rating plate.

5.2 Verification information

5.2.1 Software identification

The software identification is fully described in the user manual, and can be displayed at power up or via the software menu.

The legally relevant software is identified by two parts: ***prefix/version***.

The ***prefix*** shows the instrument model and shall be:

3590E: 01, CPWE: 01, DFW: 02, DGT: 09

The ***version*** shows the legally relevant software version shall be 01 for all series.

The ***prefix/version*** may be followed by a suffix indicating the software program version and other options installed which may be freely modified and is regarded as the non-legally relevant software.

Since the code may be longer than the digits available on the display, it is shown in two parts.

5.2.2 Calibration and programming

The programming and calibration of the instrument may be done through the keyboard of the indicator module if a specific jumper inside the indicator on the CPU board has been activated. Once the function has been enabled one accesses the general set-up menu where steps are shown on the display to help guide the operator. The calibration data is stored in a non-volatile manner in the FLASH memory and is protected by a checksum which

ascertain the integrity; in case of error the instrument's functioning is blocked. If an indicator repeater is remotely connected, the programming and calibration function is only possible on the main indicator.

6 MARKS AND INSCRIPTIONS

The instrument shall bear the following legends:

Parts (Test) Certificate number
Manufacturer's mark or name
Serial number

7 LOCATION OF SEALS AND VERIFICATION MARKS

7.1 The rating plate should be located on the indicator so that it is easily accessible and clearly visible in its regular operating position. The data plate shall be impossible to remove without it being destroyed.

7.2 Components that may not be dismantled or adjusted by the user shall be secured by a tamper-evident sealing method bearing a securing mark. The securing mark may be either:

- a mark of the manufacturer and/or manufacturer's representative, or
- an official mark of a verification officer.

8 ALTERNATIVES

8.1 Having the following set of peripheral devices "printers" which can be used in conjunction with any of the approved indicators covered by this Parts Certificate.

- DP24, DP24S1N, DP190.
- LP542, LP542S, LP542Plus, LP842Plus, LP942Plus, LP1042Plus (also called LPxx).
- TDP248M, TDP643Plus, TDP245, TTP244MEPlus, TT246MPlus (also called SMTxx).
- TM295, LX300, LX350.
- TG2460H.
- CUSTOM PLUS or TPR.
- DATAMAX: DMXM4206 e EX2.
- PR80 (alternative designation PRINT!).

All general conditions set for connectable peripheral devices stated in paragraph 4.3.1 are applicable for other peripheral devices "printers".

The peripheral devices can be connected via the following interfaces; radio-frequency (RF) or through a serial port.

8.2 Having a modified instrument, designated the KS series (Figure 29).

8.3 Having a modified 3590E instrument, with stainless steel case and graphic touch (Figure 30).

8.4 Having a modified CPWE instrument, with stainless steel case (Figures 31 and 31a).

8.5 Having the indicator connected via RS85 to a secondary display, designated the GLR100 (Figure 32). The secondary display repeats the weighing result and any other primary indication, and provides further, non-metrological information.

8.6 Having the indicator connected to a compatible Non-automatic Weighing Instrument via RS232. The indicator shall be located in proximity of the NAWI to ensure the weighing platform is visible to the operator. The indicator must be configured with the same metrological characteristics as the NAWI and be sealed as described in Section 7.2.

The Alibi memory function on the indicator can only be used if the identification of the connected NAWI is recorded as part of the measurement data.

The following functions of the indicator shall be disabled:

- Pre-set tare
- Peak Hold
- Gravity compensation

This configuration shall not be used for direct sales to the public.

9 ILLUSTRATIONS

Figure 1 - 3590E Indicator

Figure 2 - CPWE Indicator

Figure 3 - DFW Indicator

Figure 4 - DGT Indicator

Figure 5 - DFW series - ABS case version (example case 1)

Figure 6 - DFW series - ABS case version (example case 2)

Figure 7 - DFW series - ABS case version (example case 3)

Figure 7a - DFW series - ABS case version (example case 3) alternative sealing method

Figure 8 - DFW series - Stainless steel case version (example case 1)

Figure 9 - DFW series - Stainless steel case version (example case 2)

Figure 10 - DFW series - Stainless steel case version (example case 3)

Figure 10a - DFW series - Stainless steel case version (example case 3) alternative sealing method

Figure 11 - DFW series - Stainless steel case version (example case 4)

Figure 11a – DFW series - Stainless steel case version (example case 5)

Figure 12 - DFW series - Metal case version

Figure 13 - 3590E series - ABS case version (example case 1)

Figure 13a - 3590E series - ABS case version (example case 1) alternative sealing method

Figure 14 - 3590E series - ABS case version (example case 2)

Figure 15 - 3590E/DFW series - ABS case version (example case 3)

Figure 16 - 3590E series - Stainless steel case version (example case 1)

Figure 16a - 3590E series - Stainless steel case version (example case 1) alternative sealing method

Figure 17 - 3590E series - Stainless steel case and graphic touch (example case 2)

Figure 17a - 3590E series - ABS case version and graphic touch (example case 4)

Figure 17b - 3590E series - Stainless steel case and graphic touch (example case 2) alternative sealing method

Figure 17c - 3590E series - ABS case version and graphic touch (example case 4) alternative sealing method

Figure 18 - CPWE series - Aluminum case version

Figure 18a – 3590E Series – Stainless steel case and graphic touch (example case 3)

Figure 18b – 3590E Series – Stainless steel case and graphic touch (example case 3) alternative sealing method

Figure 19 - CPWE series - Stainless steel case version

Figure 19a - CPWE series - Stainless steel case version alternative sealing method

Figure 20 - DGT series - Plastic case version (example case 1)

Figure 21 - DGT series - Plastic case version (example case 2)

Figure 22 - DGT series - Plastic case version (example case 3)

Figure 23 - DGT series - Plastic case version (example case 4)

Figure 24 - DGT series - Metal case version (example case 1)

Figure 25 - DGT series - Metal case version (example case 2)

Figure 25a - DGT series - Metal case version (example case 2) alternative sealing method

Figure 26 - DGT series - Stainless steel case version (example case 1)

Figure 27 - DGT series - Stainless steel case version (example case 2)

Figure 28 - Examples of connections between indicators and load cells

Figure 29 - KS series – Stainless steel case version

Figure 30 - 3590E Series – Stainless steel case and graphic touch (example case 4)

Figure 30a - 3590E Series – Stainless steel case and graphic touch (example case 4) alternative sealing method

Figure 31 - CPWE Series – Stainless steel case (example case 2)

Figure 31a - CPWE Series – Stainless steel case (example case 2) alternative sealing method

Figure 32 - GLR100 secondary display (alternative 8.5)

CERTIFICATE HISTORY

| ISSUE NO. | DATE | DESCRIPTION |
|---------------------|-------------------|--|
| GB-1461 | 21 September 2012 | Test Certificate first issued. |
| GB-1461 Revision 1 | 01 November 2013 | Changes made to pages 1, 2, [multi-interval, or multi-range weighing options , section 3.1 [200 m/mm ²], DGT table on page 12 [addition of serial Nos.], and addition of figures 5 to 23. |
| GB-1461 Revision 2 | 09 May 2014 | New indicators 3590EQ, DGT100 & DGT1S added to certificate. Section 7.1 created to add peripheral devices “printers”. Test report SN: 1282 added to descriptive annex. Technical characteristics table amended to correct typo. Addition of Figures: 24, 25 & 26 |
| GB-1461 Revision 3 | 13 November 2014 | Modifications to the following sections; 1, 2.1, 4.1, 5.2.1, 8 and associated illustrations. |
| GB-1461 Revision 4 | 26 March 2015 | Change of Figure 9 |
| GB-1461 Revision 5 | 27 April 2015 | Addition of Figures: 11a, 17a & 18a. Printer PR80 (PRINT!) added to Section 7.1 |
| GB-1461 Revision 6 | 06 July 2015 | Maximum load cell impedance changed to 3 k Ω in Section 3.1. |
| GB-1461 Revision 7 | 11 April 2016 | Section 7.2 added. KS series test report added to Appendix. |
| GB-1461 Revision 8 | 12 May 2016 | References to 2009/23/EC replaced by 2014/31/EU. Compliance to EN45501:1992 changed to EN45501:2015. |
| GB-1461 Revision 9 | 27 July 2017 | Reference to Evaluation Report added to the front page. Section 4.3 renumbered 4.2. Section 7 added, previous Section 7 changed to Section 8. Section 8.3 added. |
| GB-1461 Revision 10 | 22 December 2017 | Sections 8.4, Figure 31 and Figure 31a added. Addition of Figures 7a, 10a, 13a, 16a, 17b, 17c, 18b, 19a, 25a and 30a for alternative sealing methods. Section 9 modified accordingly. |

| | | |
|---------------------|---------------|--|
| GB-1461 Revision 11 | 05 March 2018 | Span tests added for DGT and 3590E in Section Tests carried out. |
| GB-1461 Revision 12 | 28 June 2018 | Section 8.5 and Figure 32 added. |
| GB-1461 Revision 13 | 13 July 2018 | Section 8.6 added. |

APPENDIX TO DESCRIPTIVE ANNEX

TESTS CARRIED OUT

The following tests were performed with the indicators connected to a load cell simulator or to a weighing platform.

DFW Series:

All testing conducted by CIBE Metrological Laboratory, Italy

| EN45501 Ref | Test | Test Report № |
|-------------|---|-------------------------|
| A.5.3.2 | Temperature effect on no load indication | 0906/0907 |
| A.5.4 | Voltage variations | 0906/0907 |
| B.3.1 | Short time power reductions | 0906/0907 |
| B.3.2 | Electrical Bursts | 0906/0907 |
| B.3.3 | Electrostatic discharges | 0906/0907 |
| B.3.4 | Immunity to radiated electromagnetic fields | GSD Laboratory POLAB |
| A.5.3.1 | Weighing performance at static temperatures | 0906/0907 |
| B.3.5 | Immunity to radiated electromagnetic fields | 0906/0907 |
| B.3.3 | Surge | 0906/0907 |
| B.2.2 | Damp heat steady state | 0906/0907 |
| A.4.10 | Repeatability | 0906/0907 |
| A.4.12 | Stability of equilibrium | 0906/0907 |
| A.4.6.1 | Tares | 0906/0907 |
| A.5.2 | Warm-up | 0906/0907 |

DGT Series:

All testing conducted by CIBE Metrological Laboratory, Italy

| EN45501 Ref | Test | Test Report № |
|-------------|---|----------------|
| A.5.3.2 | Temperature effect on no load indication | 0501 |
| A.5.4 | Voltage variations | 0501 |
| B.3.1 | Short time power reductions | 0501 |
| B.3.2 | Electrical Bursts | 0501 |
| B.3.3 | Electrostatic discharges | 0501 |
| B.3.4 | Immunity to radiated electromagnetic fields | GSD Laboratory |
| A.5.3.1 | Weighing performance at static temperatures | 0501 |
| B.2.2 | Damp heat steady state | 0501 |
| A.4.10 | Repeatability | 0501 |
| A.4.12 | Stability of equilibrium | 0501 |
| A.4.6.1 | Tares | 0501 |
| A.5.2 | Warm-up | 0501 |
| A.4.2.1 | Zero setting range | 0501 |
| B.4 | Span | 0501 |

3590E

All testing conducted by CIBE Metrological Laboratory, Italy

| EN45501 Ref | Test | Test Report № |
|-------------|---|---------------|
| A.5.3.2 | Temperature effect on no load indication | 0306 |
| A.5.4 | Voltage variations | 0306 |
| B.3.1 | Short time power reductions | 0306 |
| B.3.2 | Electrical Bursts | 0306 |
| B.3.3 | Electrostatic discharges | 0306 |
| B.3.4 | Immunity to radiated electromagnetic fields | 0306 |
| A.5.3.1 | Weighing performance at static temperatures | 0306 |
| B.2.2 | Damp heat steady state | 0306 |
| A.4.10 | Repeatability | 0306 |
| A.4.12 | Stability of equilibrium | 0306 |
| A.4.6.1 | Tares | 0306 |
| A.5.2 | Warm-up | 0306 |
| B.4 | Span | 0306 |

3590EXP

All testing conducted by CIBE Metrological Laboratory, Italy

| EN45501 Ref | Test | Test Report № |
|-------------|---|---------------|
| A.5.3.2 | Temperature effect on no load indication | 0905/1012 |
| A.5.4 | Voltage variations | 0905/1012 |
| B.3.1 | Short time power reductions | 0905/1012 |
| B.3.2 | Electrical Bursts | 0905/1012 |
| B.3.3 | Electrostatic discharges | 0905/1012 |
| B.3.4 | Immunity to radiated electromagnetic fields | 0905/1012 |
| A.5.3.1 | Weighing performance at static temperatures | 0905/1012 |
| B.2.2 | Damp heat steady state | 0905/1012 |
| A.4.10 | Repeatability | 0905/1012 |
| A.4.12 | Stability of equilibrium | 0905/1012 |
| A.4.6.1 | Tares | 0905/1012 |
| A.5.2 | Warm-up | 0905/1012 |

3590E and CPWE Series

*All testing conducted by NMO

| EN45501 Ref | Test | Test Report № |
|-------------|---|-------------------|
| B.3.2 | Electrical Bursts (3590EXPCC) | SN:1193 |
| B.3.4 | Electrostatic discharges (3590EXPCC & 3590EXP) | SN:1193, SN: 1282 |
| B.3.5 | Immunity to radiated electromagnetic fields (3590EXT 3590EXPCC & CPWET) | SN:1193 |
| B.3.6 | Immunity to conducted electromagnetic fields (3590EXT, 3590EXPCC & CPWET) | SN:1193 |
| B.3.3 | Surge (3590EXPCC) | SN:1193 |
| - | Cable length between indicator and load cell (3590EXPCC) | SN:1193 |

DFW

*All testing conducted by NMO

| EN45501 Ref | Test | Test Report № |
|-------------|---|---------------|
| B.3.4 | Electrostatic discharges (DFWK06XP, DFWL, DFWDXT & DFWB) | SN:1232 |
| B.3.5 | Immunity to radiated electromagnetic fields (DFWK06XP, DFWL, DFWDXT & DFWB) | SN:1232 |
| B.3.1 | AC mains voltage dips and short interruptions (DFWDXT) | SN:1232 |

DGT

*All testing conducted by NMO

| EN45501 Ref | Test | Test Report № |
|-------------|--|--|
| B.3.2 | Electrical Bursts (DGT1S) | SN: 1282 |
| B.3.3 | Surge (DGT1S) | SN: 1282 |
| B.3.4 | Electrostatic discharges (DGT4PB,DGTQ, DGTPK, DGT60AN & DGT100) | SN:1228, SN:1229, SN:1230, SN:1231, SN: 1282 |
| B.3.5 | Immunity to radiated electromagnetic fields (DGT4PB, DGTQ, DGTPK, DGT60AN & DGT1S) | SN:1228, SN:1229, SN:1230, SN:123, SN: 1282 |
| B.3.1 | AC mains voltage dips and short interruptions (DGTPK) | SN:1229 |
| B.3.6 | Immunity to conducted electromagnetic fields (DGT4PB) | SN:1230 |

*Note: EMC testing conducted at the levels required in OIML R76 (2006)

KS series

*All testing conducted by ELETTRA

| EN45501 Ref | Test | Test Report № |
|-------------|---|-------------------|
| B.3.4 | Electrostatic discharges | R-EM-555-0316-05B |
| B.3.5 | Immunity to radiated electromagnetic fields | R-EM-555-0316-05B |

*Note: EMC testing conducted at the levels required in OIML R76 (2006)



Figure 1 – 3590 Indicator



Figure 2 – CPWE Indicator



Figure 3 – DFW Indicator



Figure 4 – DGT Indicator

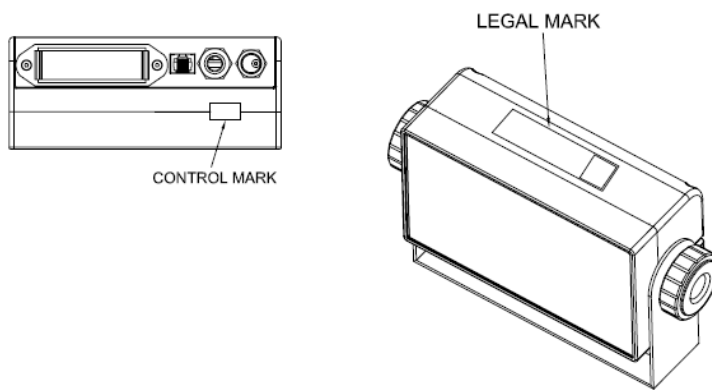
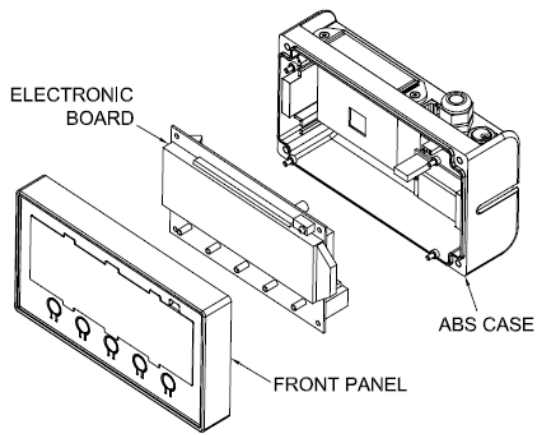

alternative sealing method

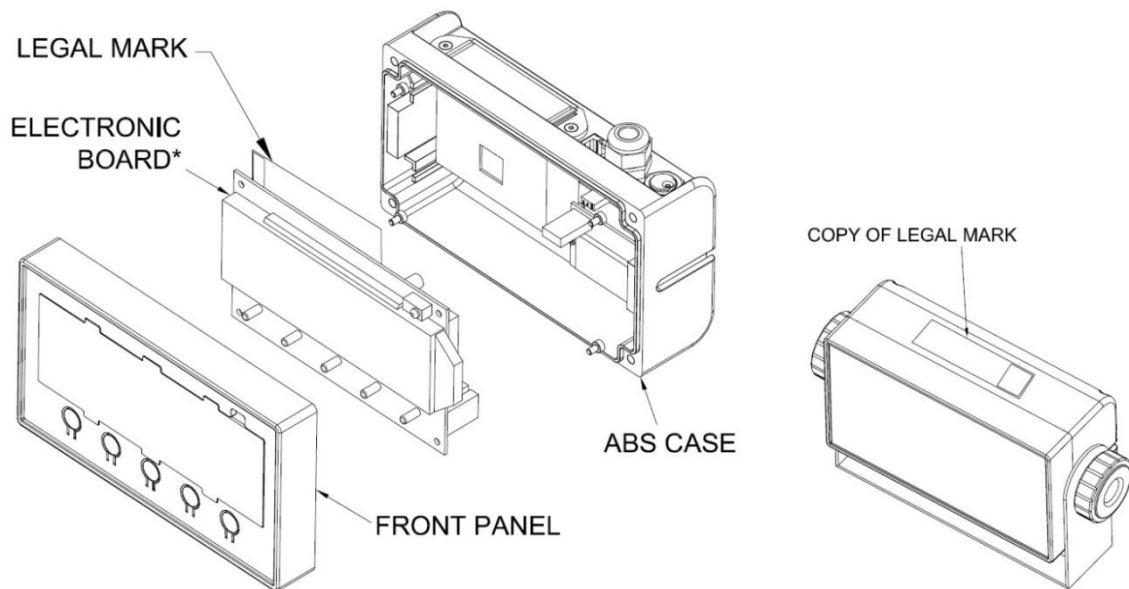

(*) Control and Legal Mark on electronic board

Figure 5 – DFW series - ABS case version (example case 1)

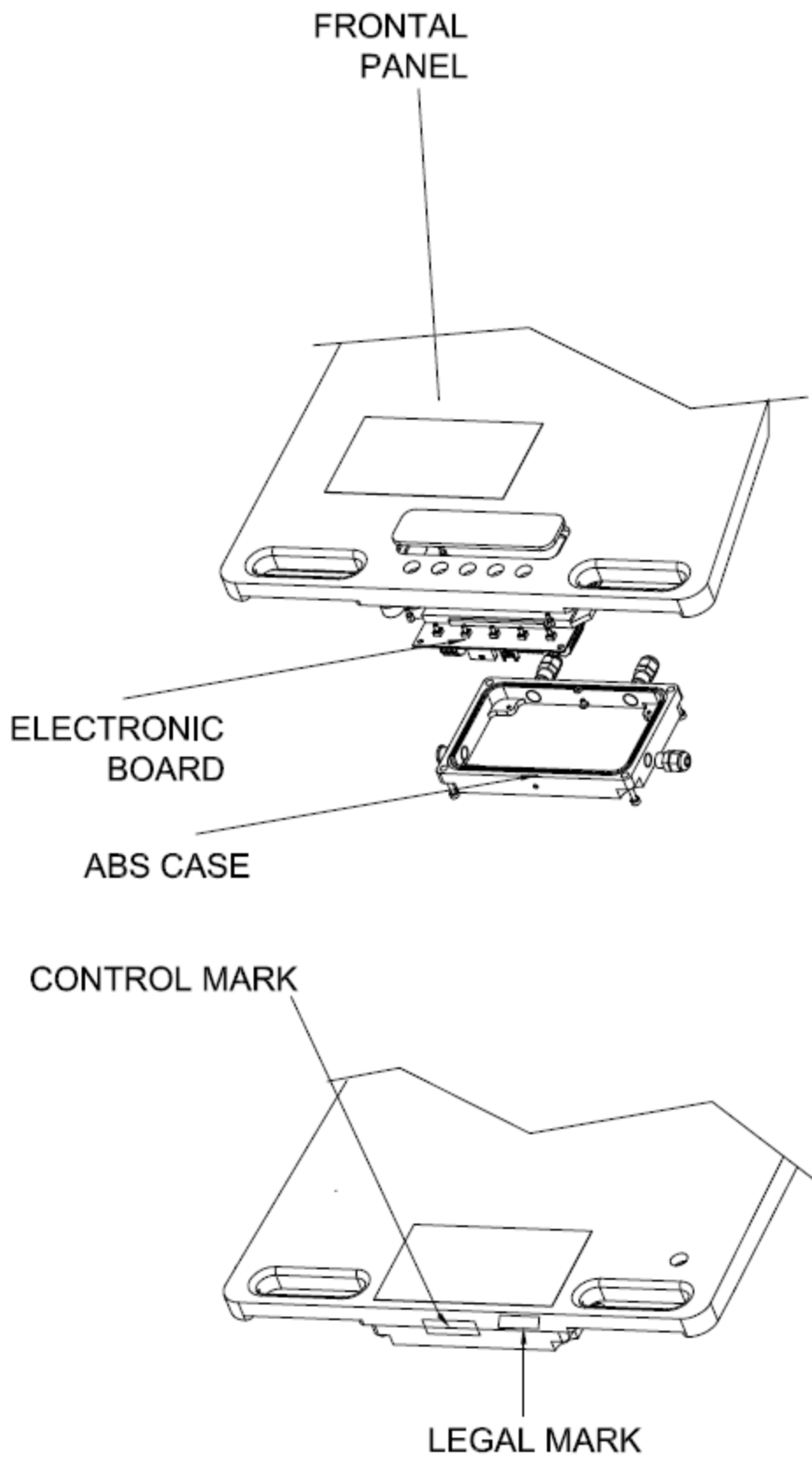

Figure 6 - DFW series - ABS case version (example case 2)

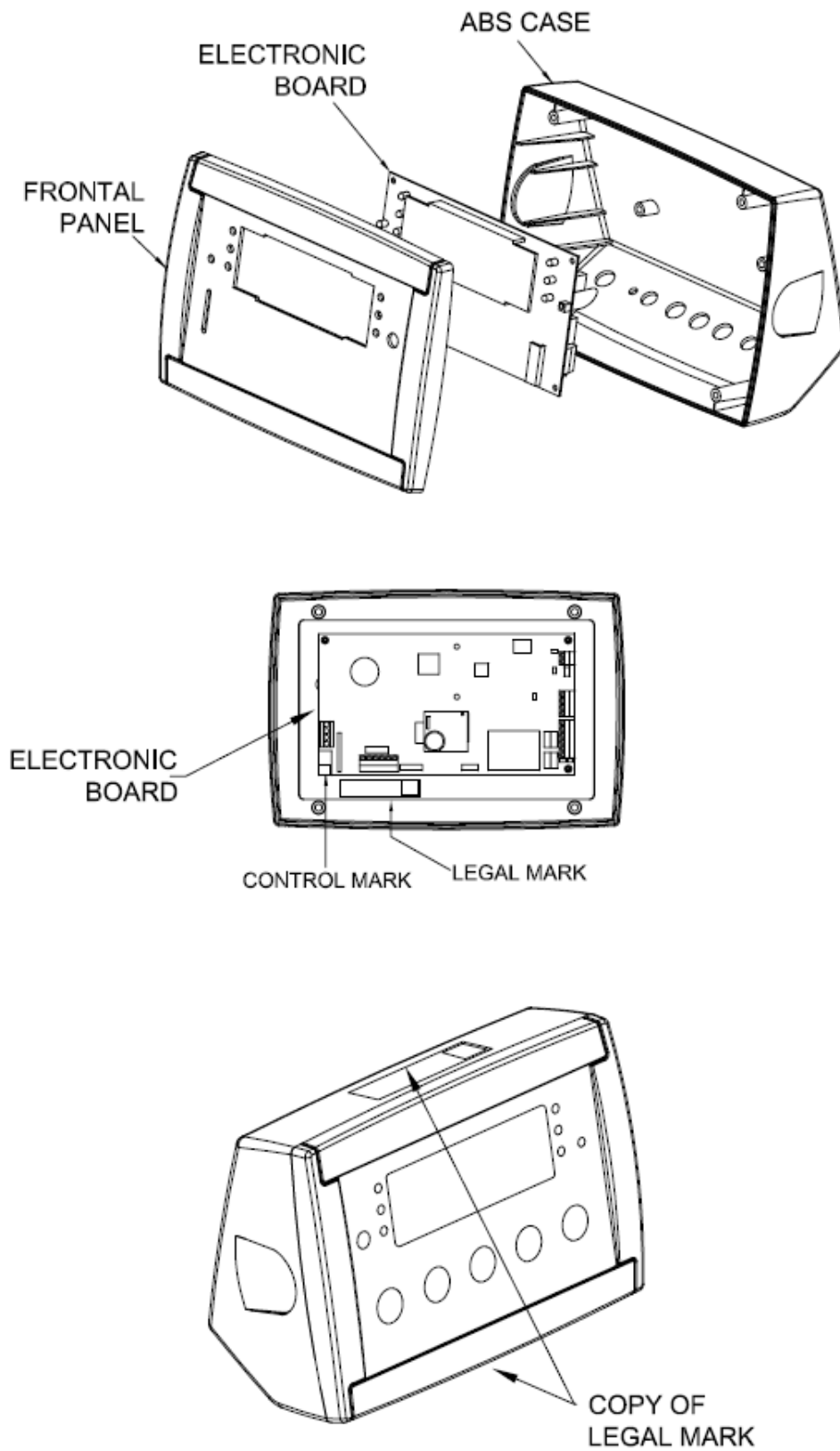

Figure 7 – DFW series - ABS case version (example case 3)

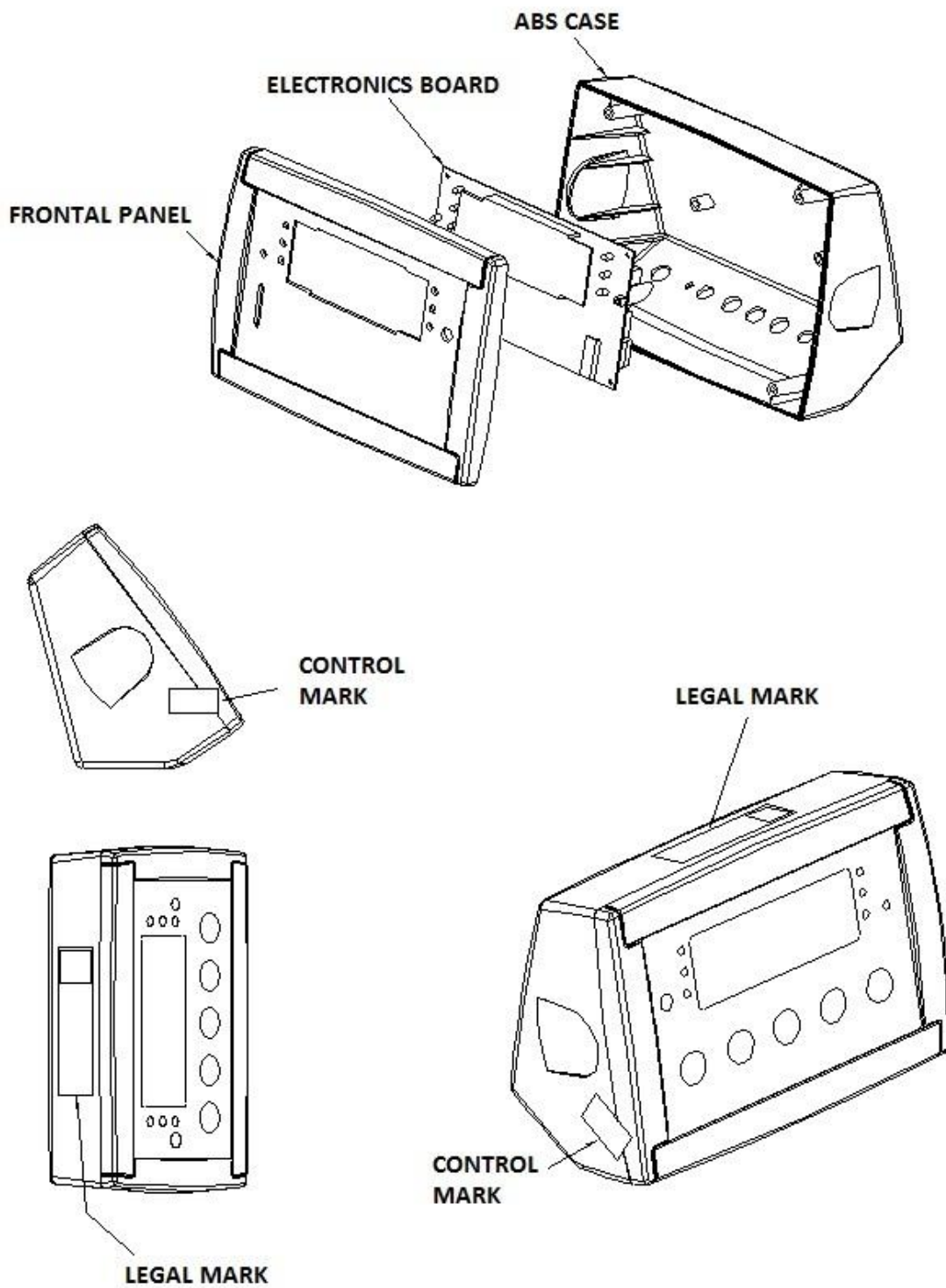
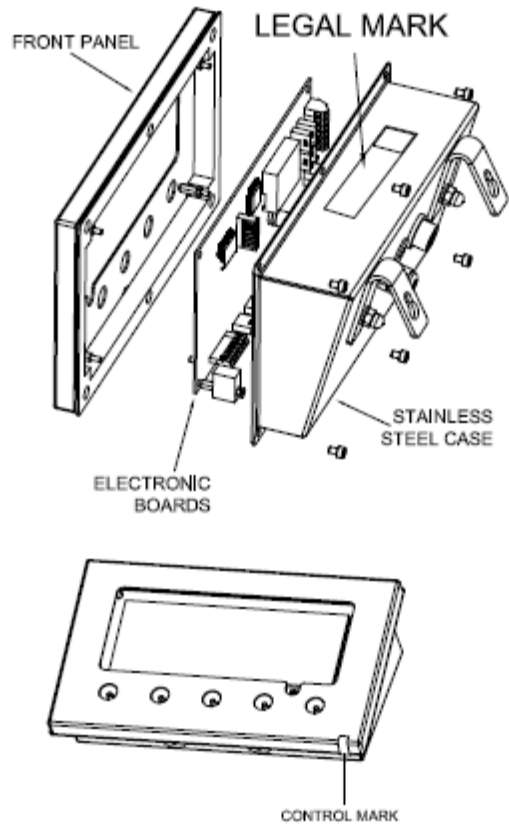
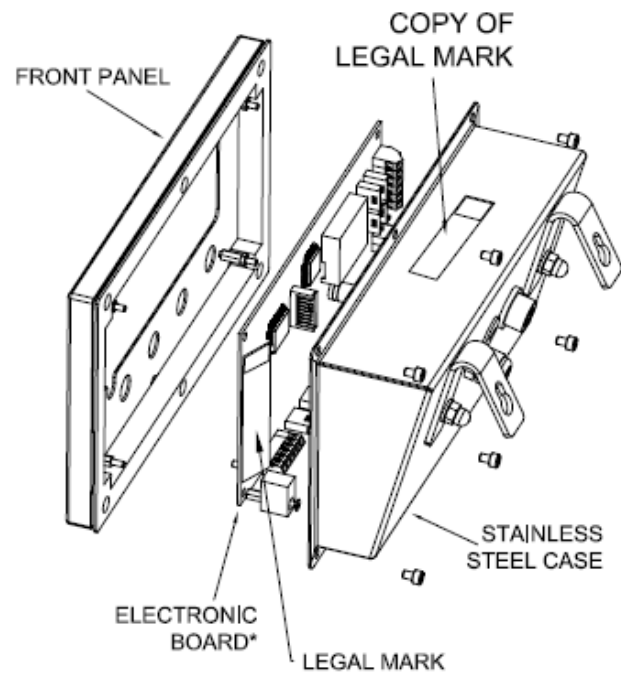

Figure 7a – DFW series - ABS case version (example case 3) alternative sealing method



alternative sealing method



*Control mark on electronic board

Figure 8 – DFW series - Stainless steel case version (example case 1)

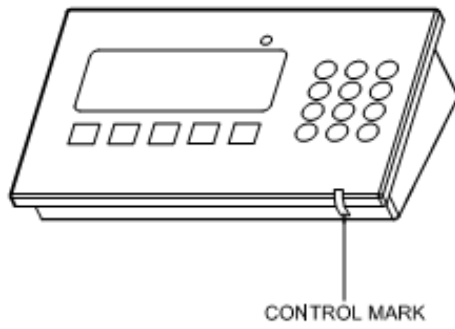
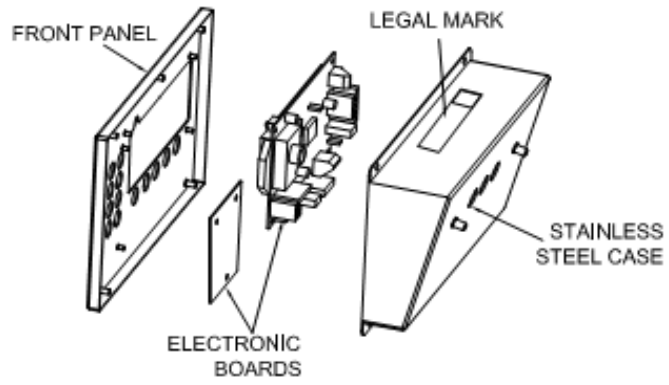

Or

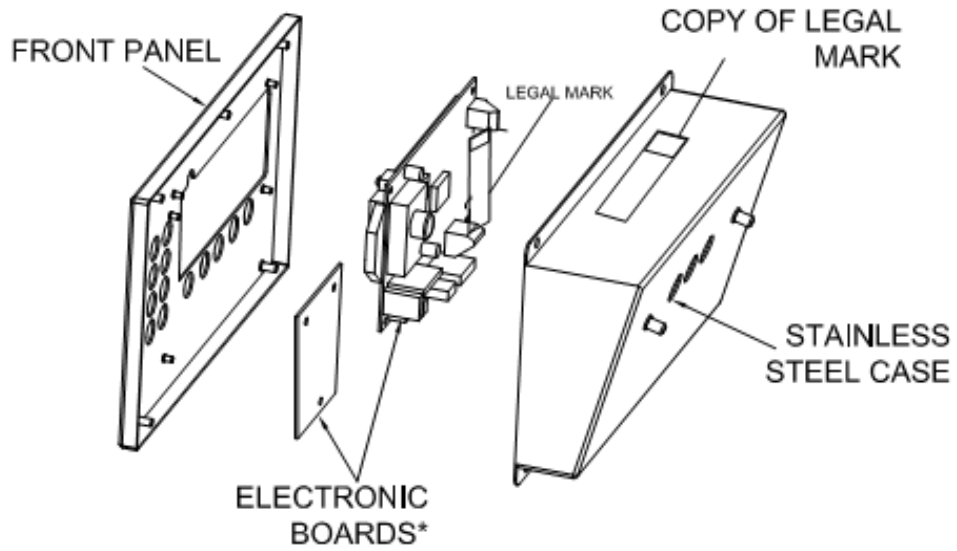

*Control mark on electronic board

Figure 9 – DFW series - Stainless steel case version (example case 2)

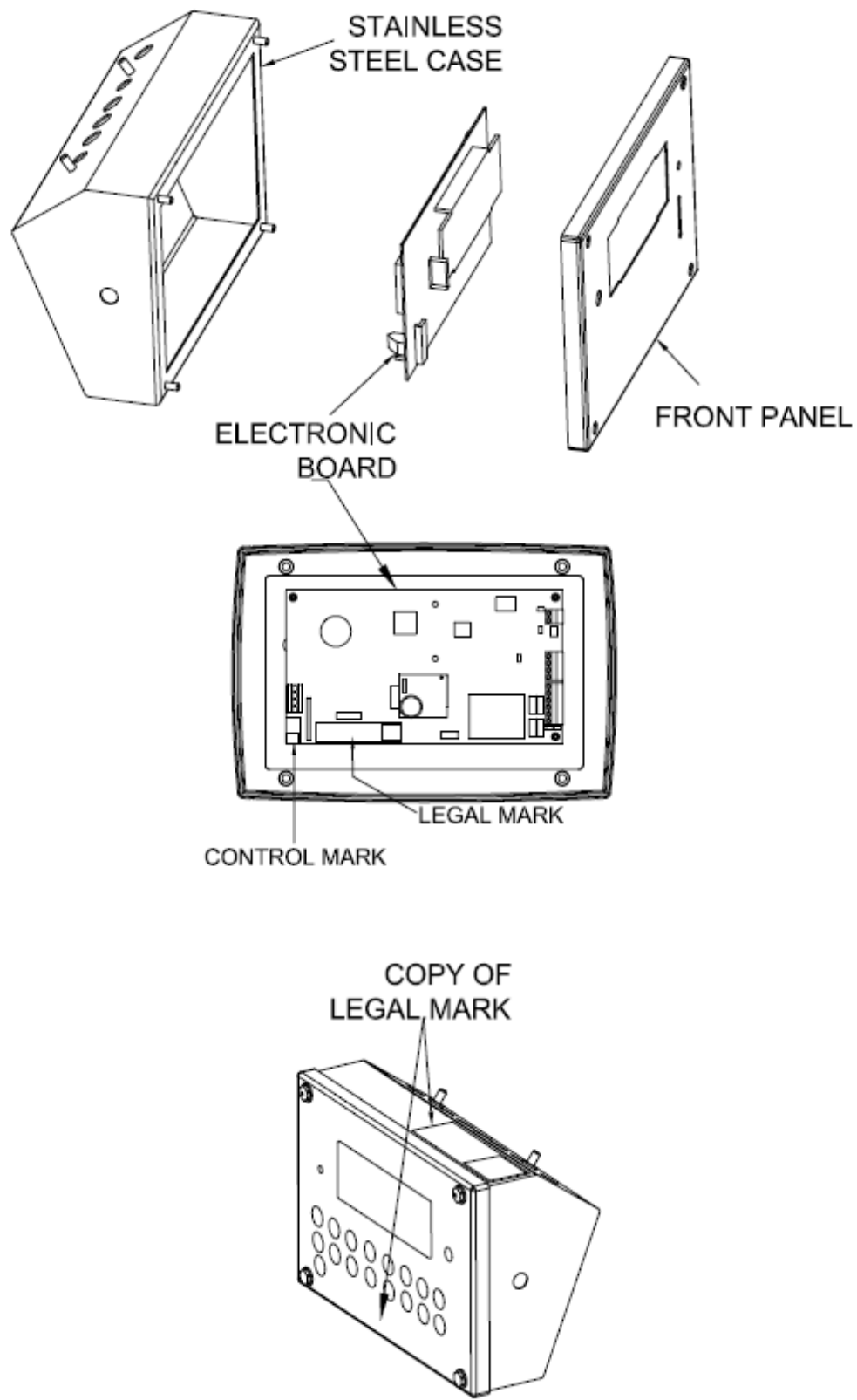

Figure 10 – DFW series - Stainless steel case version (example case 3)

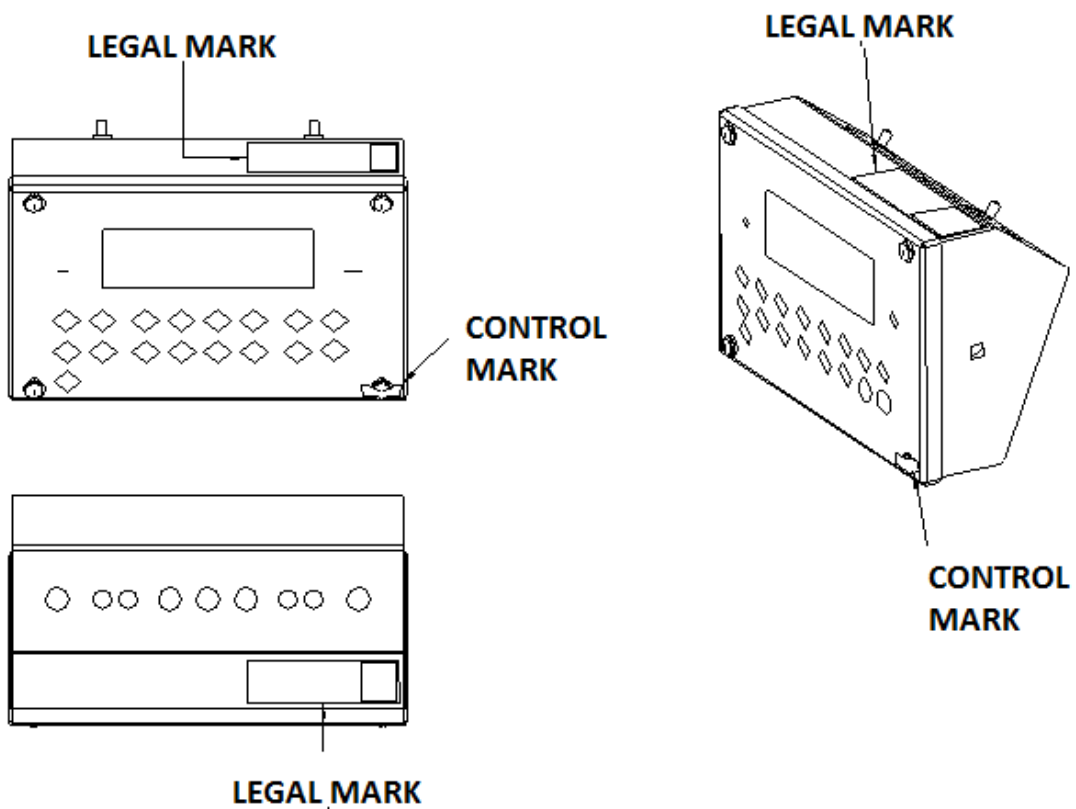
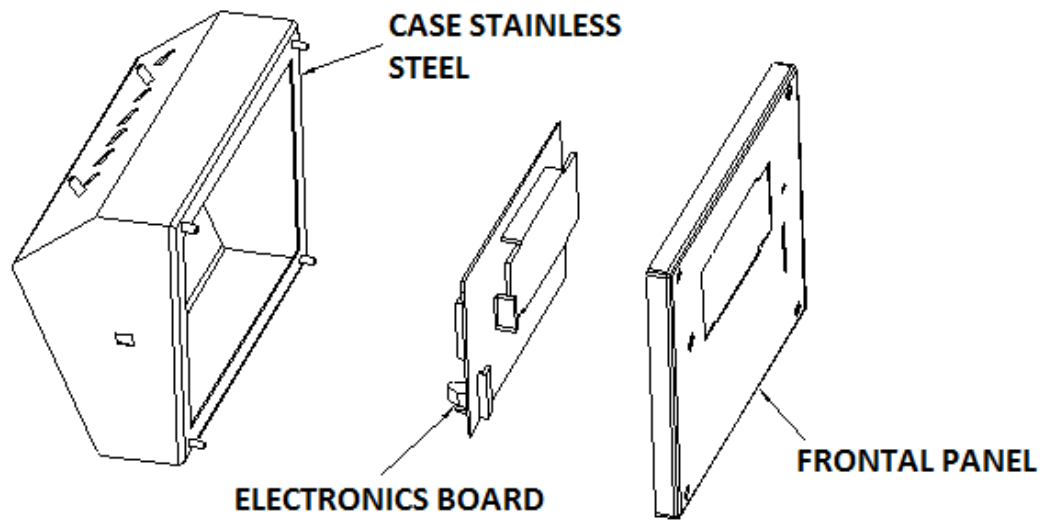

Figure 10a – DFW series - Stainless steel case version (example case 3) alternative sealing method

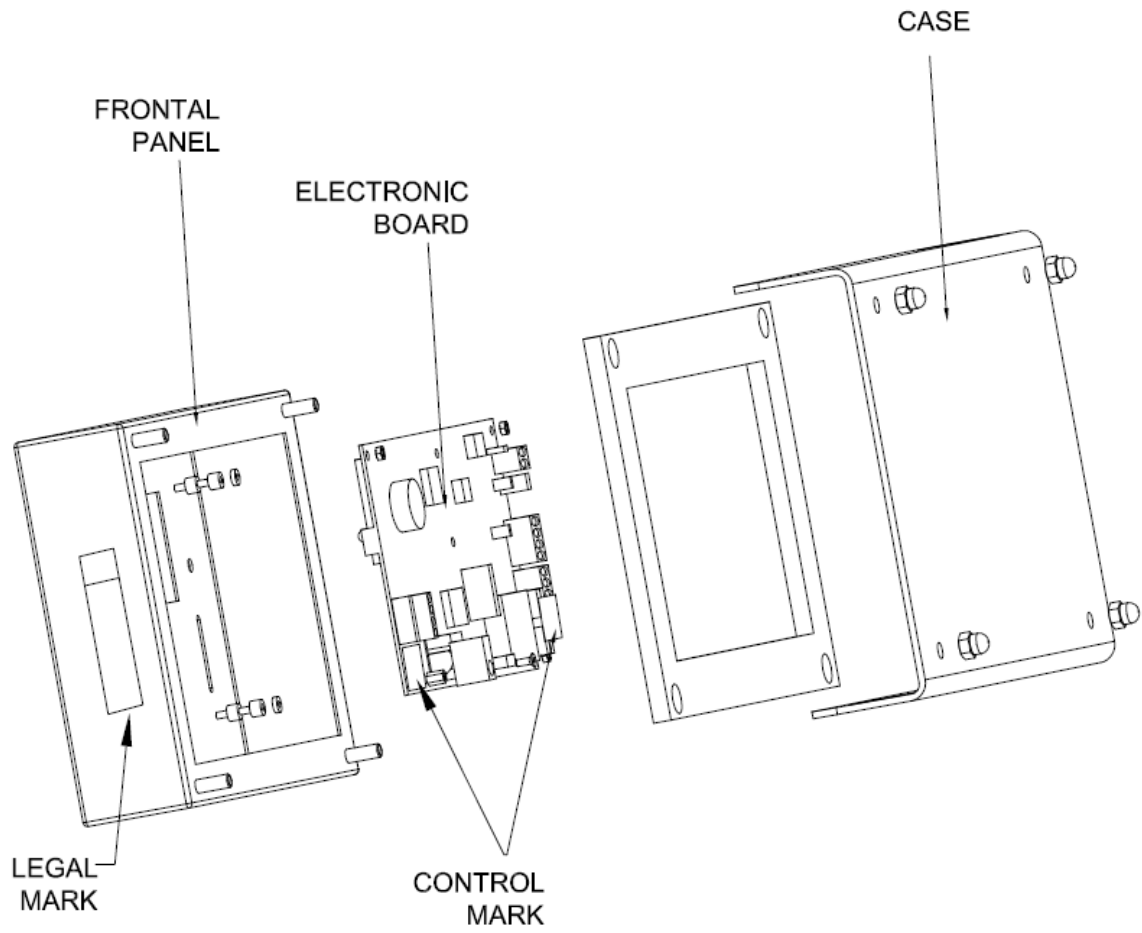

Figure 11– DFW series - Stainless steel case version (example case 4)

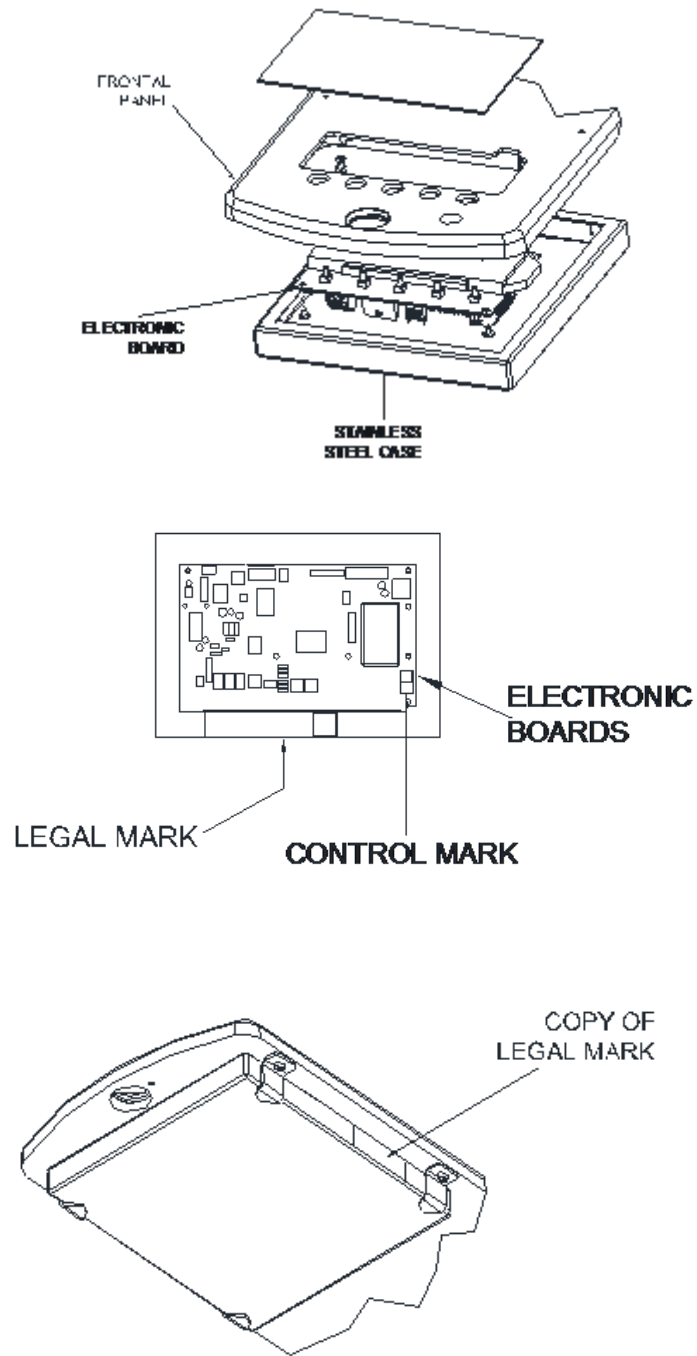

Figure 11a – DFW series - Stainless steel case version (example case 5)

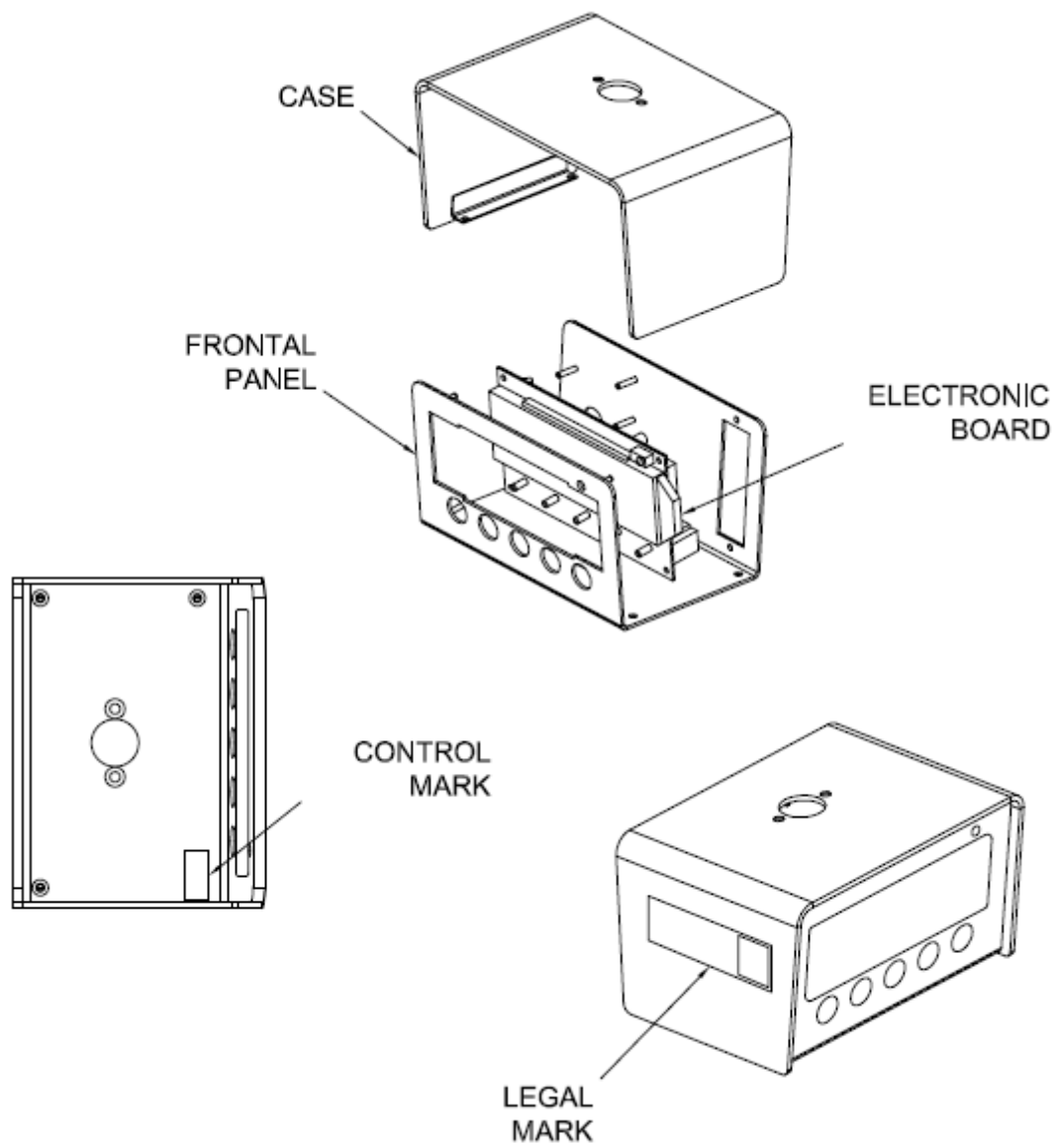

Figure 12 - DFW series - Metal case version

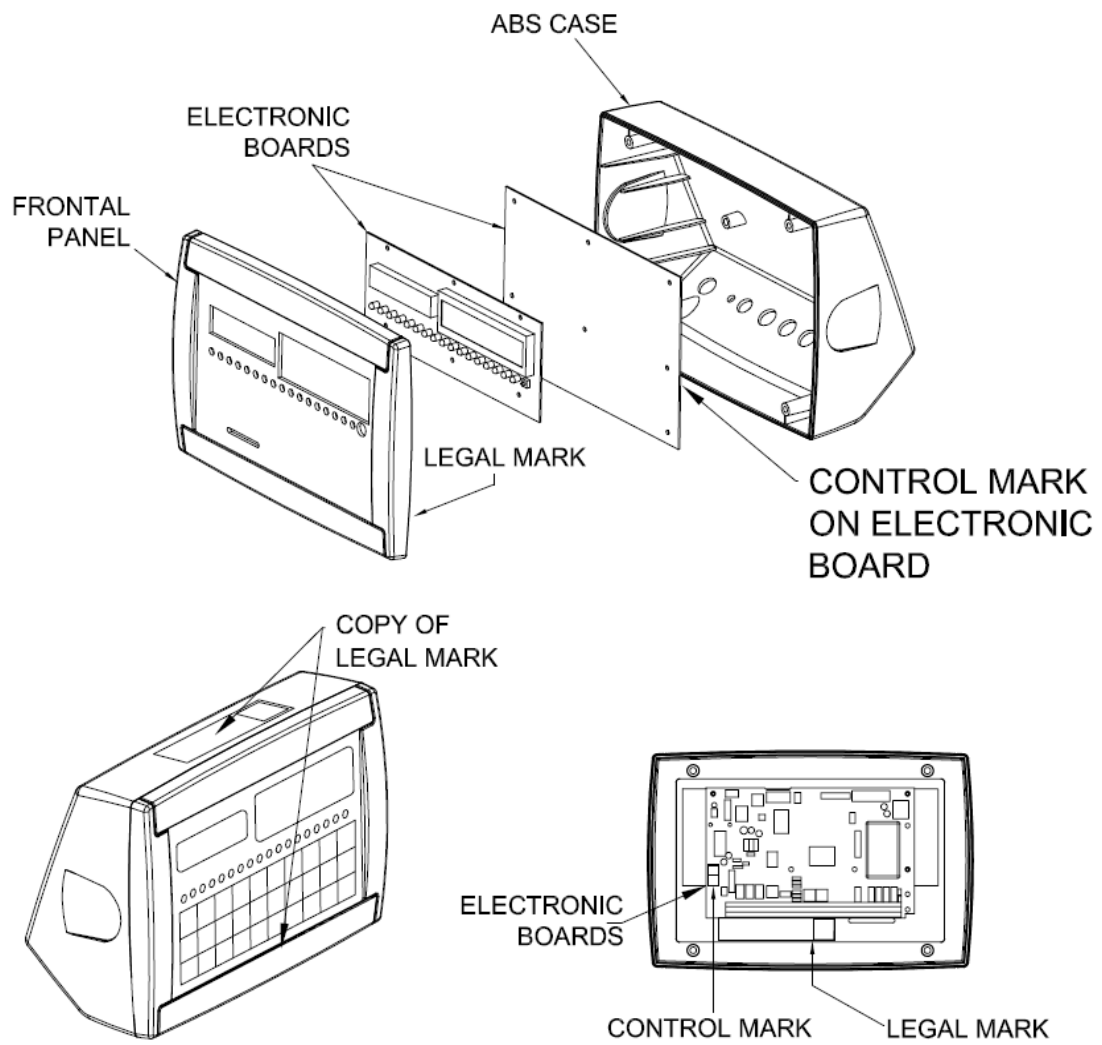

Figure 13 – 3590E series - ABS case version (example case 1)

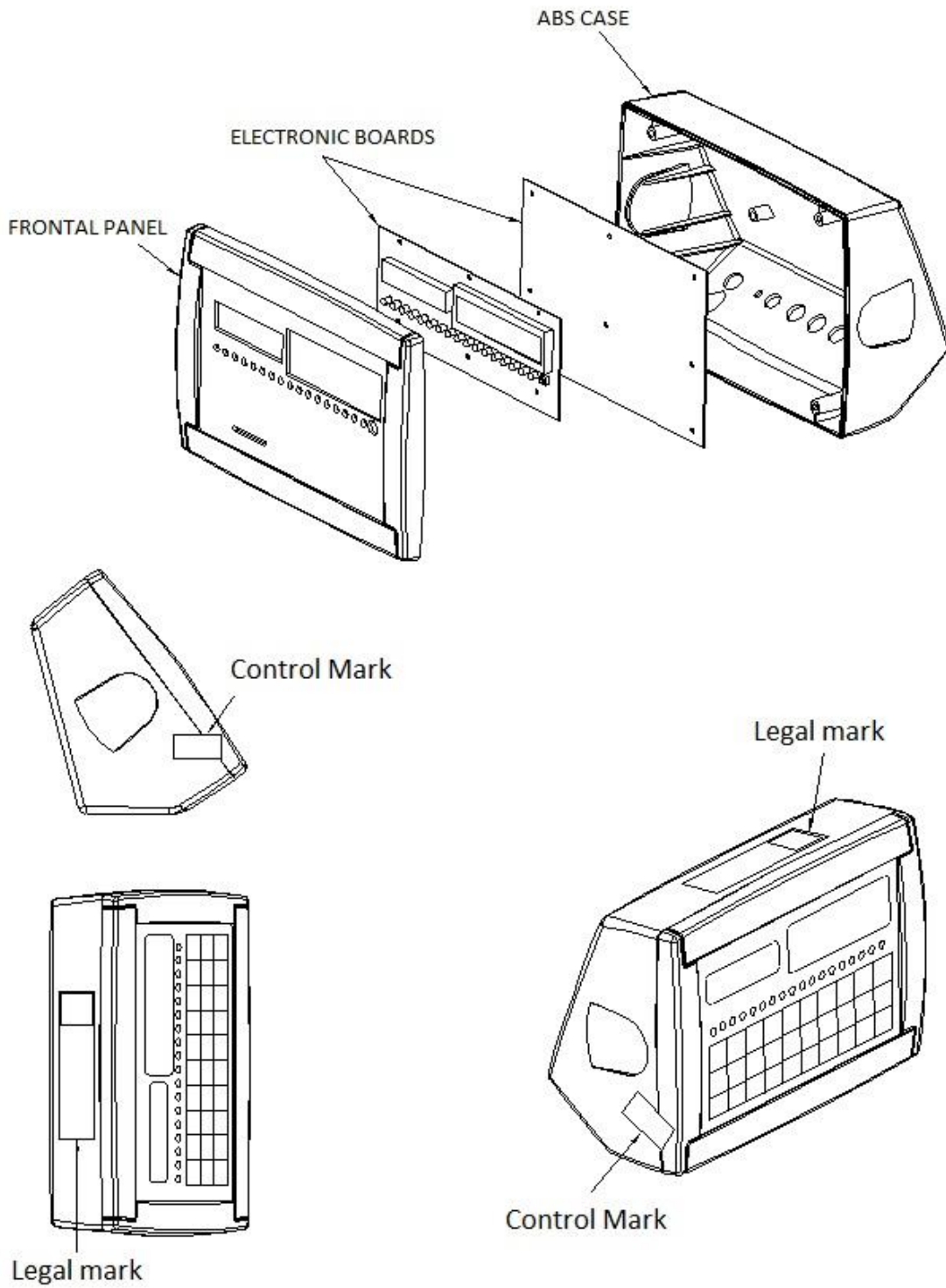

Figure 13a – 3590E series - ABS case version (example case 1) alternative sealing method

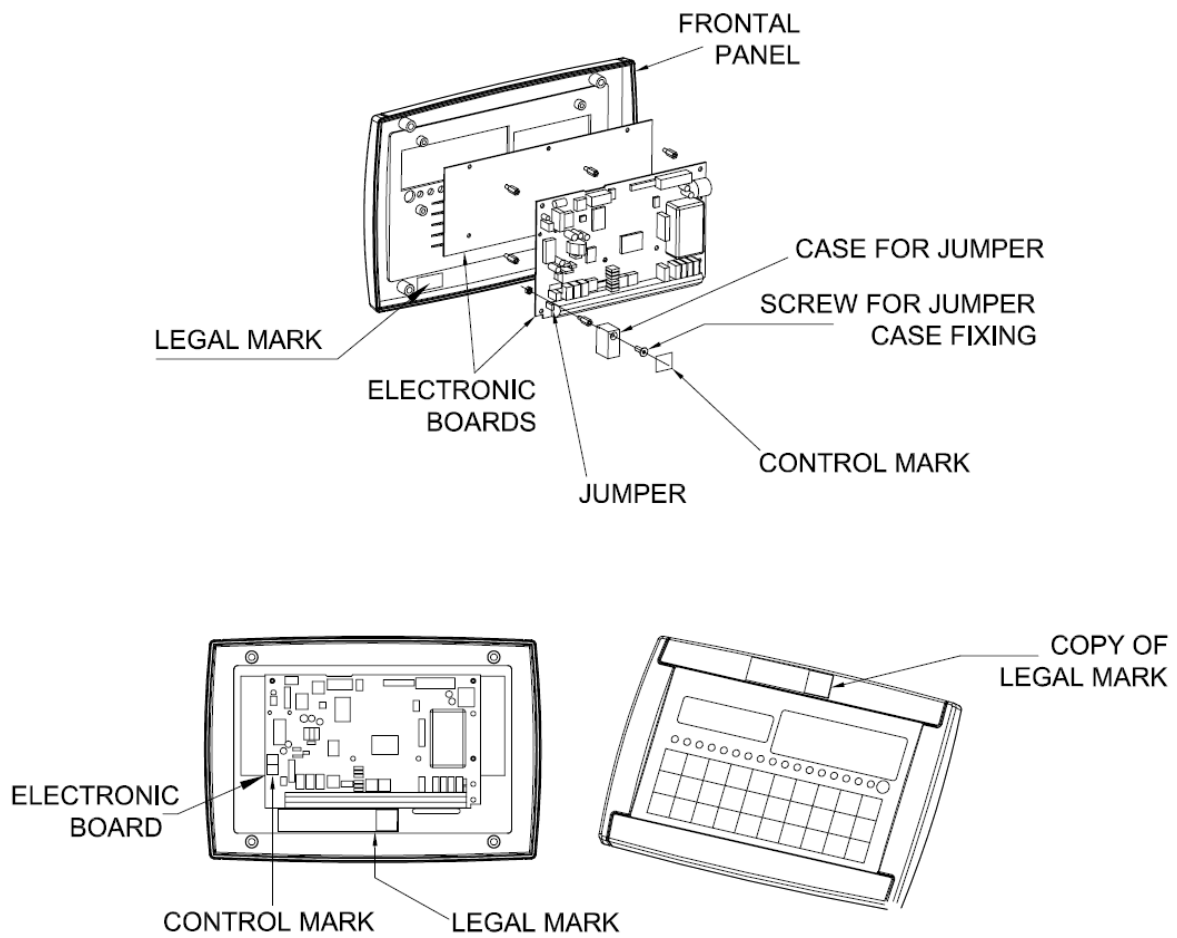

Figure 14 – 3590E series - ABS case version (example case 2)

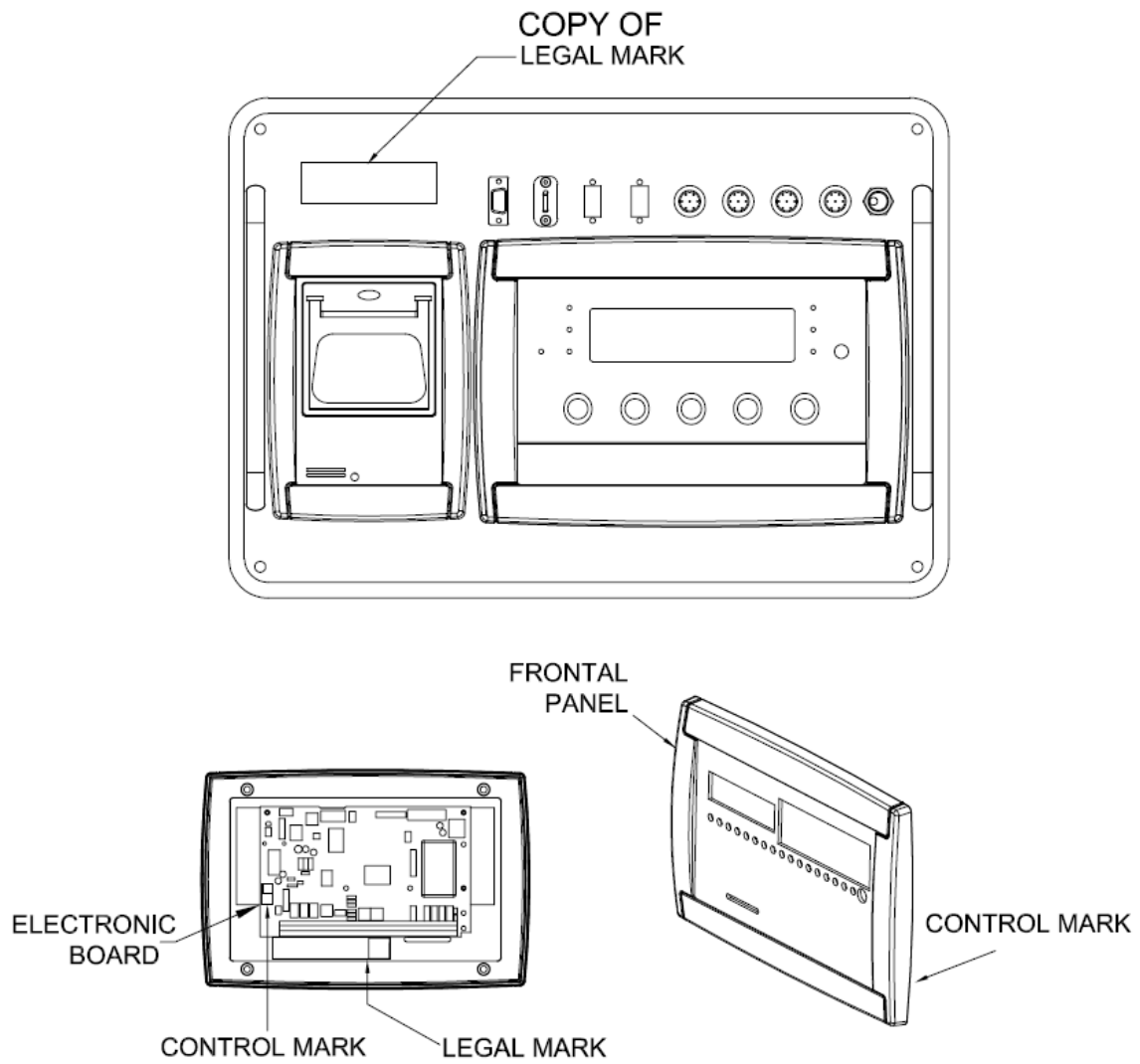

Figure 15 – 3590E/DFW series - ABS case version (example case 3)

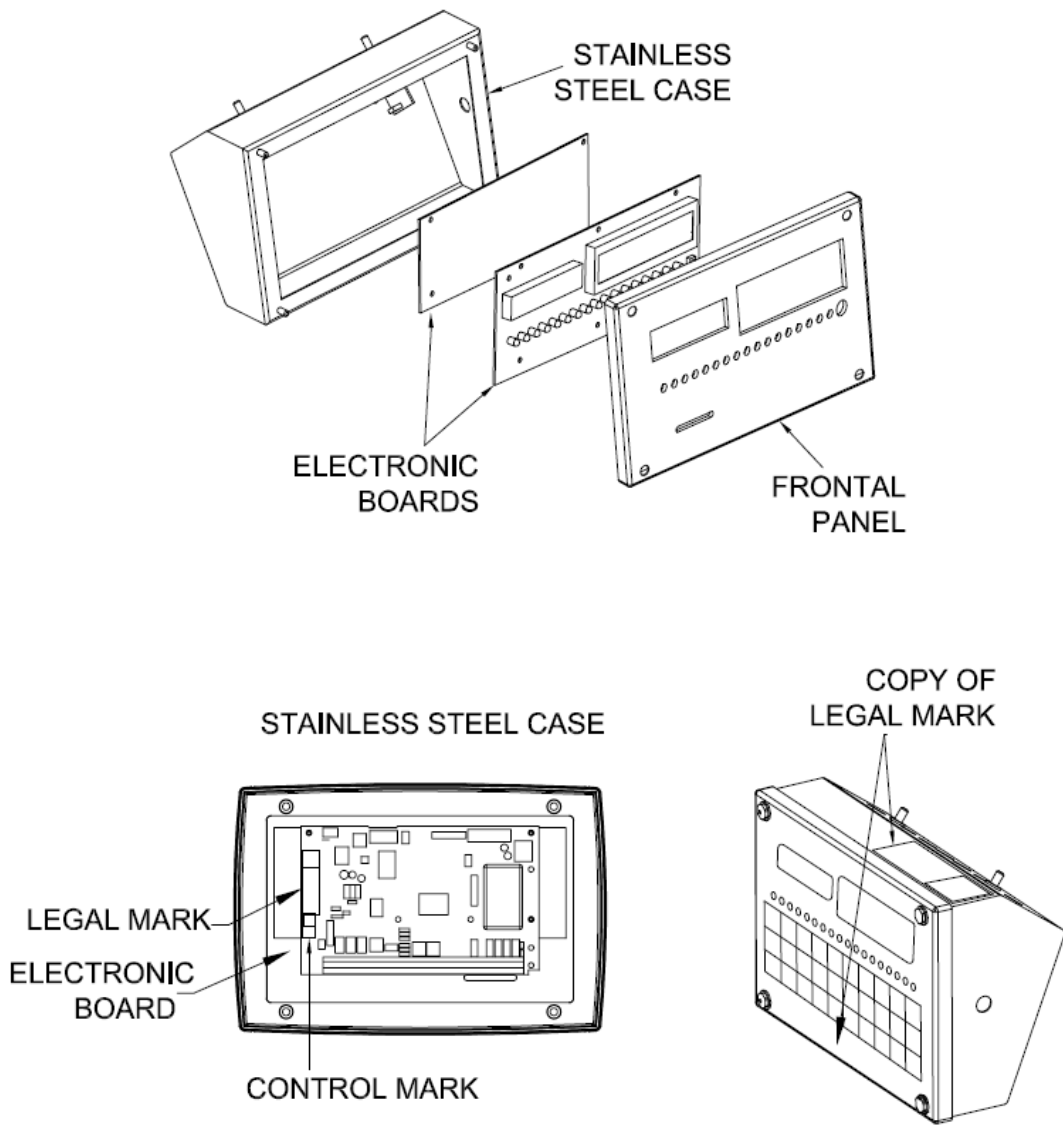

Figure 16 – 3590E series - Stainless steel case version (example case 1)

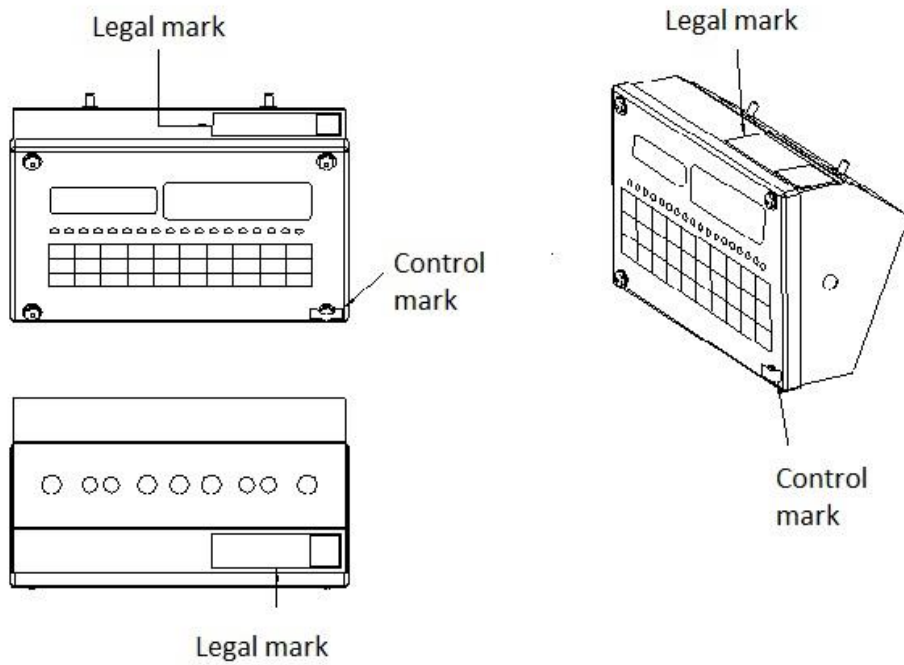
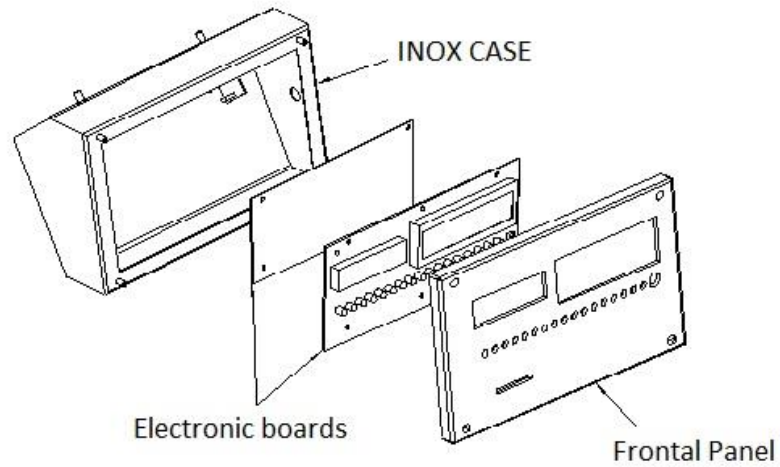

Figure 16a – 3590E series - Stainless steel case version (example case 1) alternative sealing method

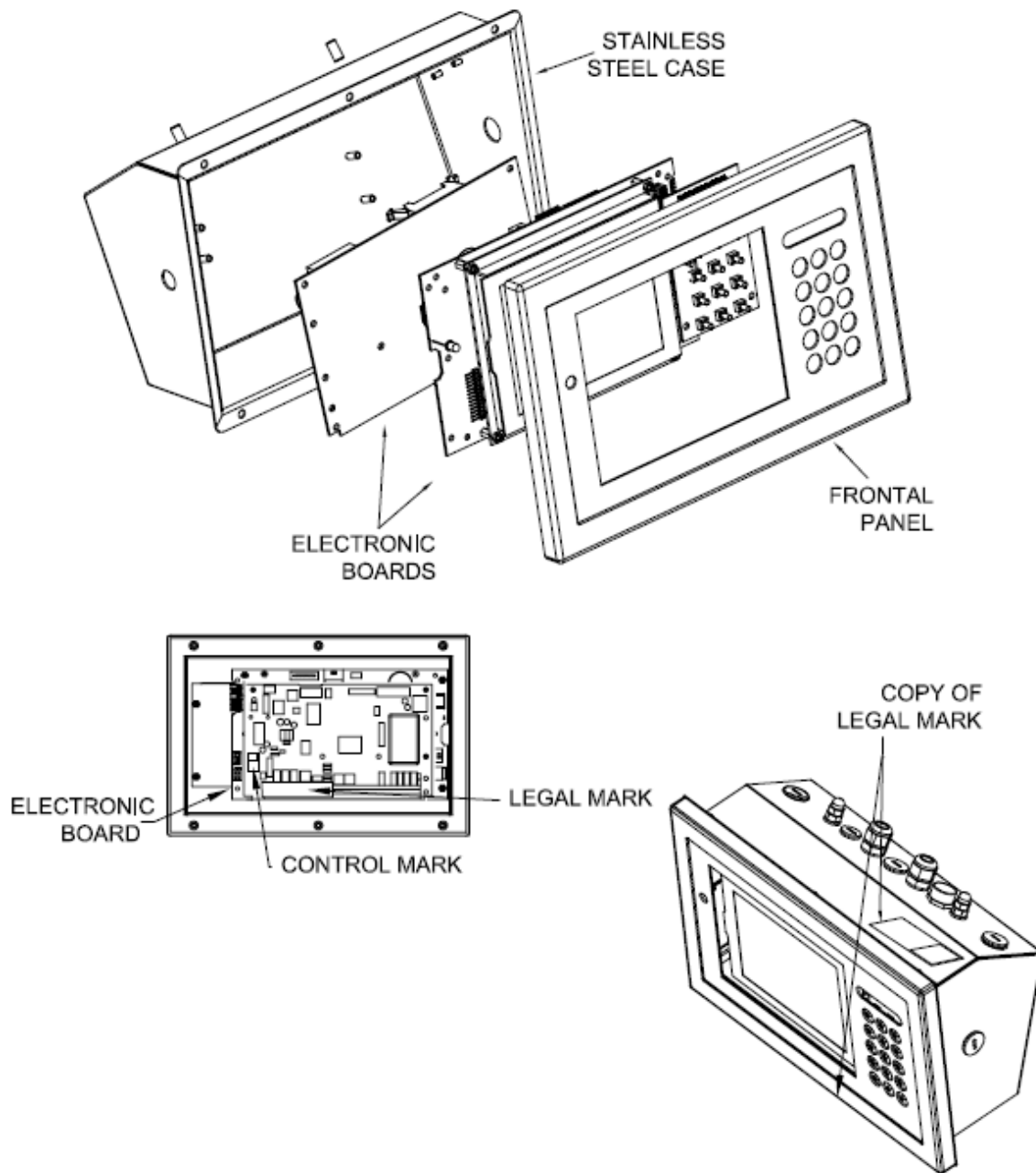

Figure 17 – 3590E series - Stainless steel case and graphic touch (example case 2)

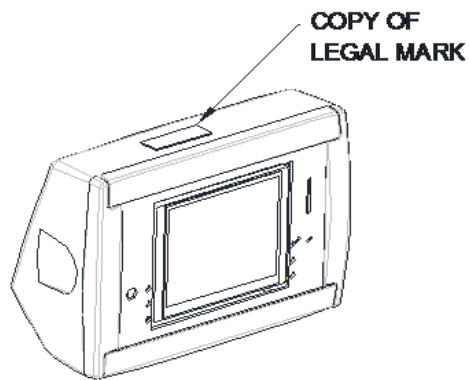
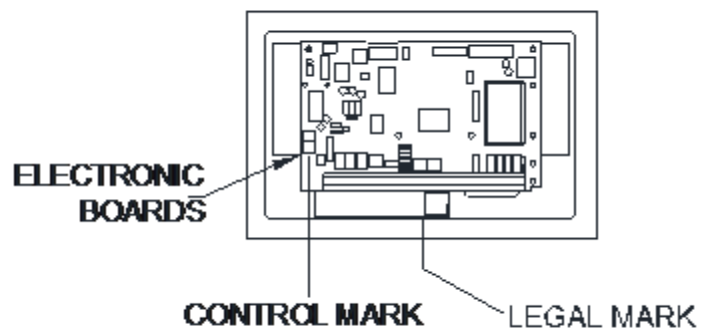
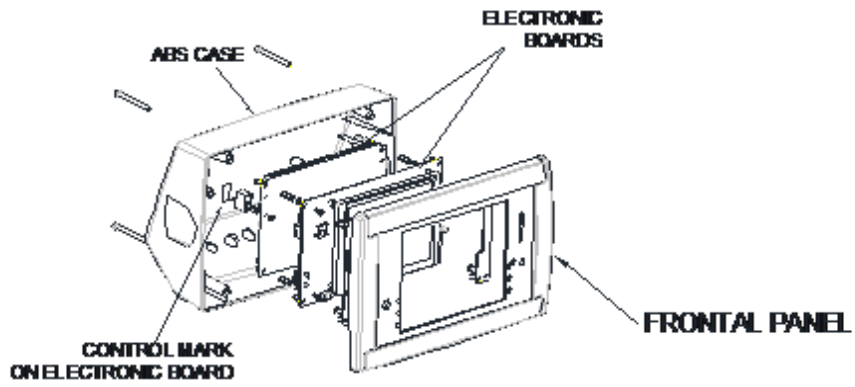

Figure 17a – 3590E series - ABS case version and graphic touch (example case 4)

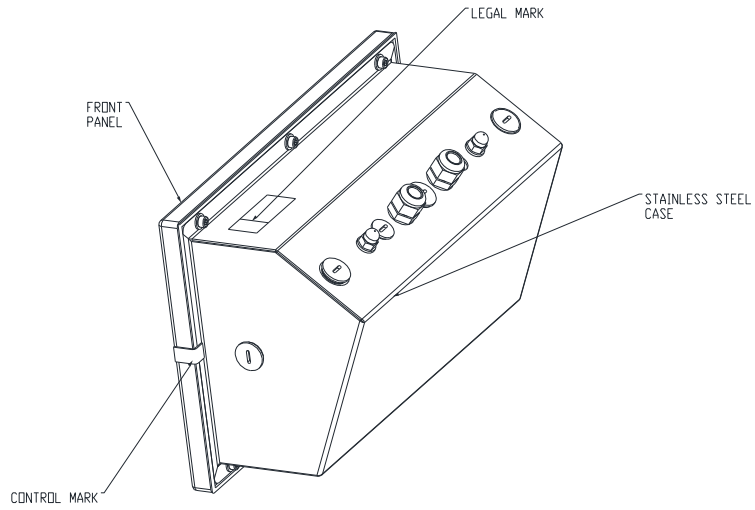

Figure 17b – 3590E series - Stainless steel case and graphic touch (example case 2) alternative sealing method

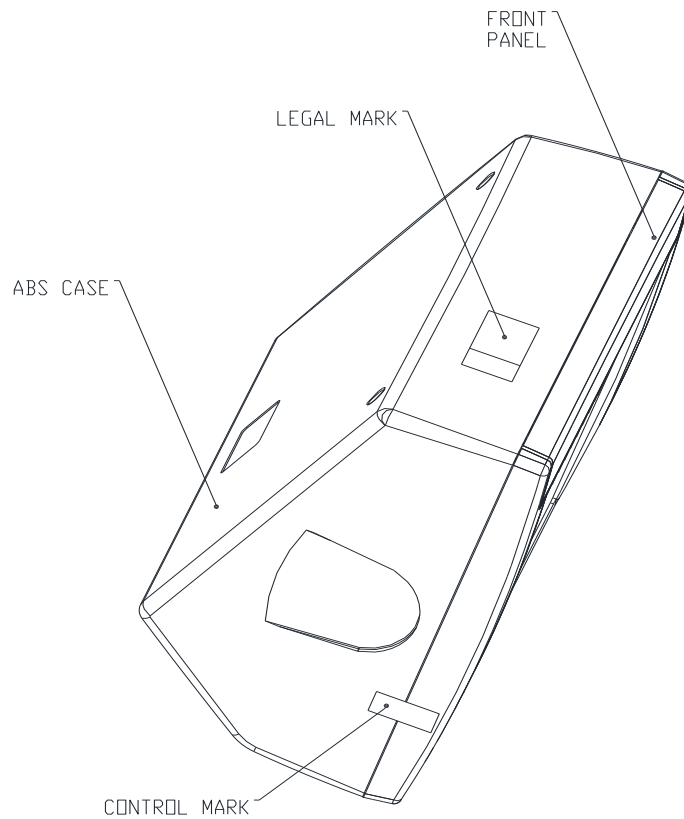

Figure 17c – 3590E series - ABS case version and graphic touch (example case 4) alternative sealing method

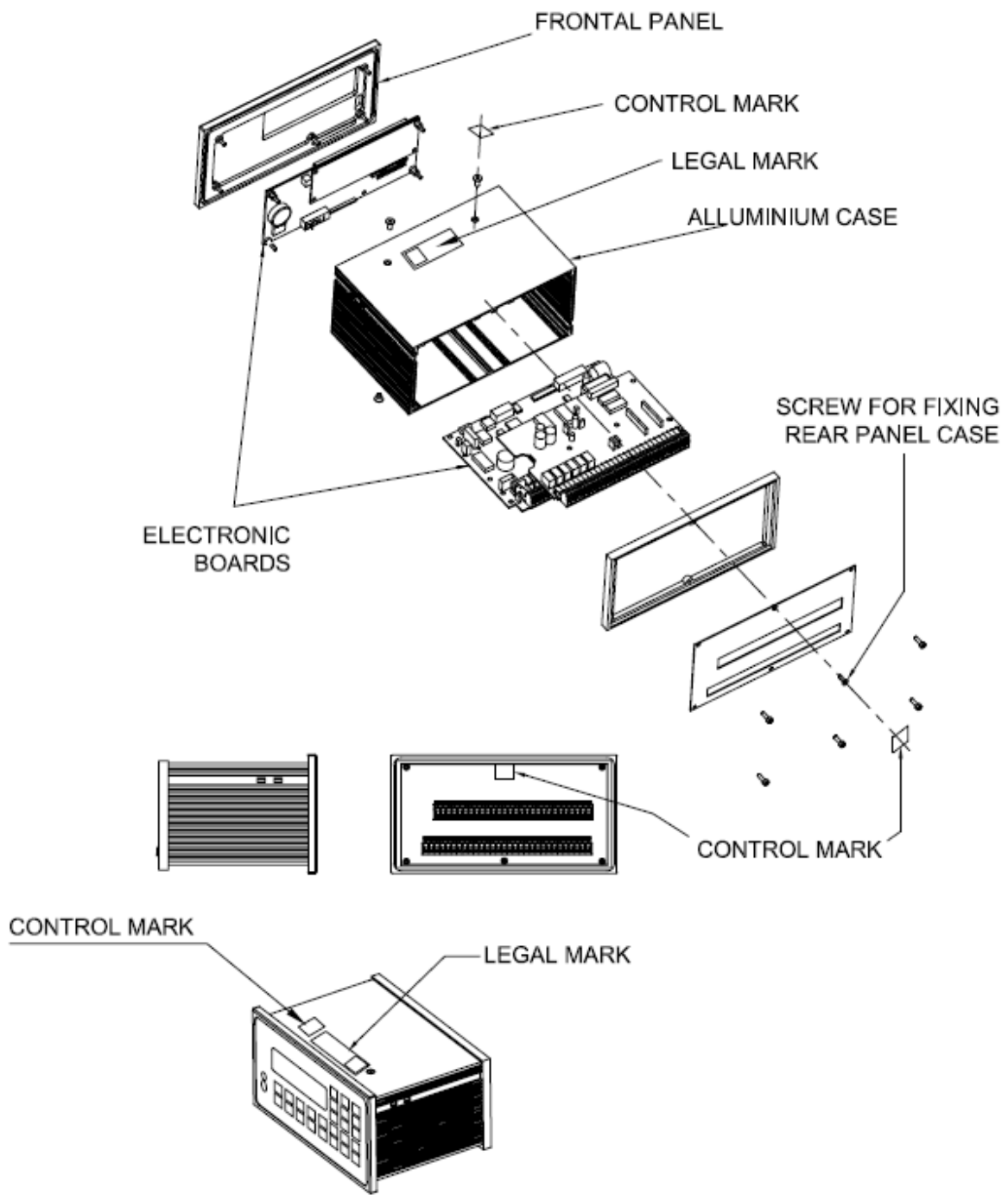

Figure 18 – CPWE series - Aluminium case version

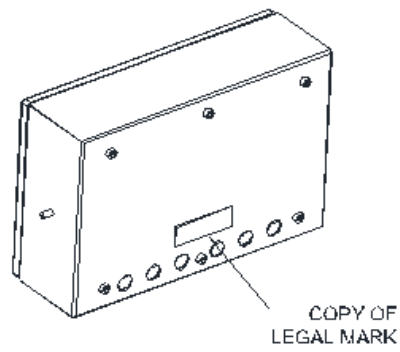
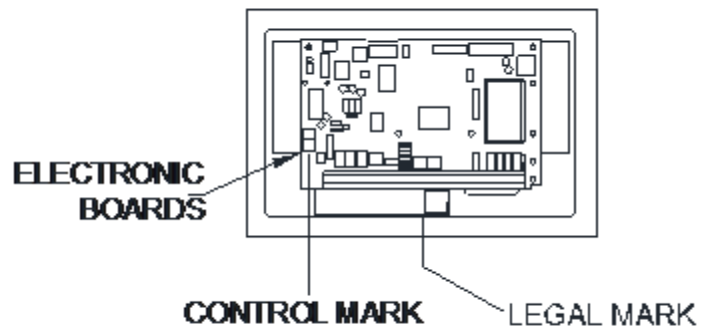
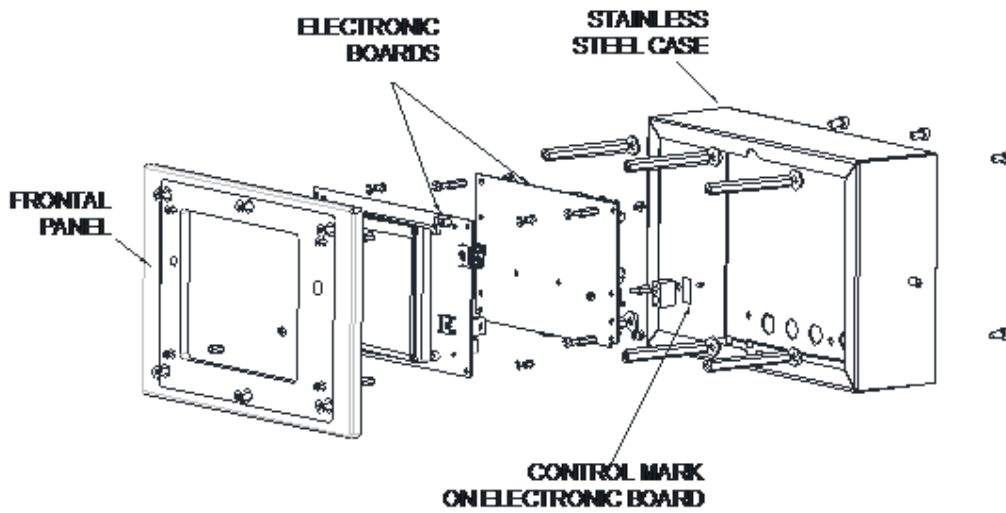

Figure 18a – 3590E Series – Stainless steel case and graphic touch (example case 3)

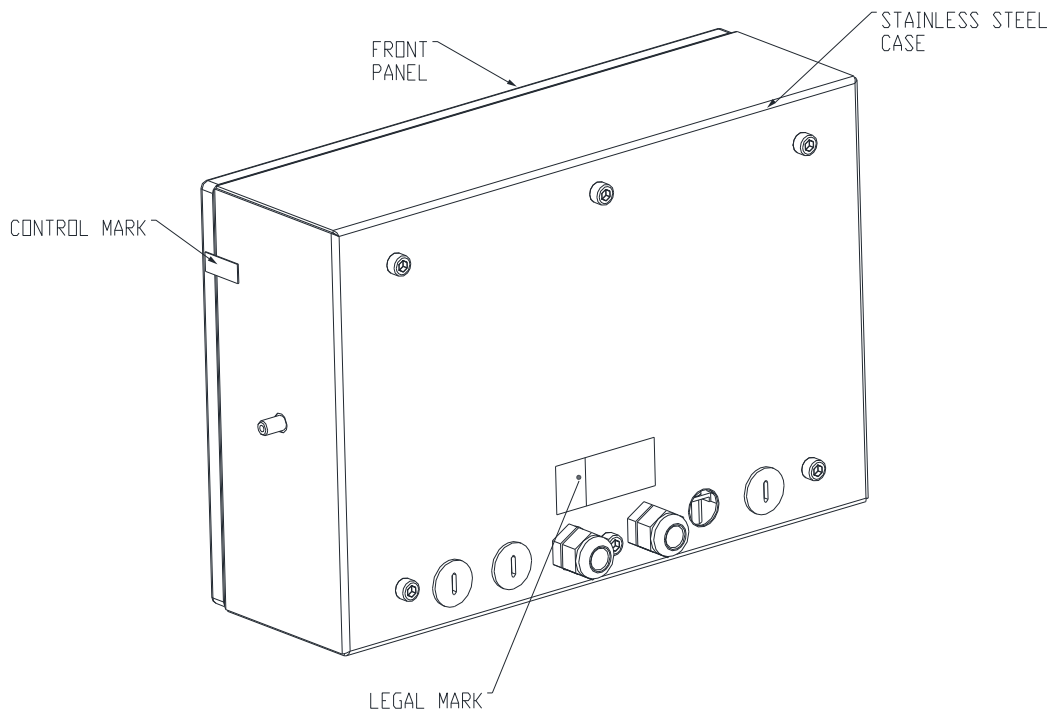

Figure 18b – 3590E Series – Stainless steel case and graphic touch (example case 3) alternative sealing method

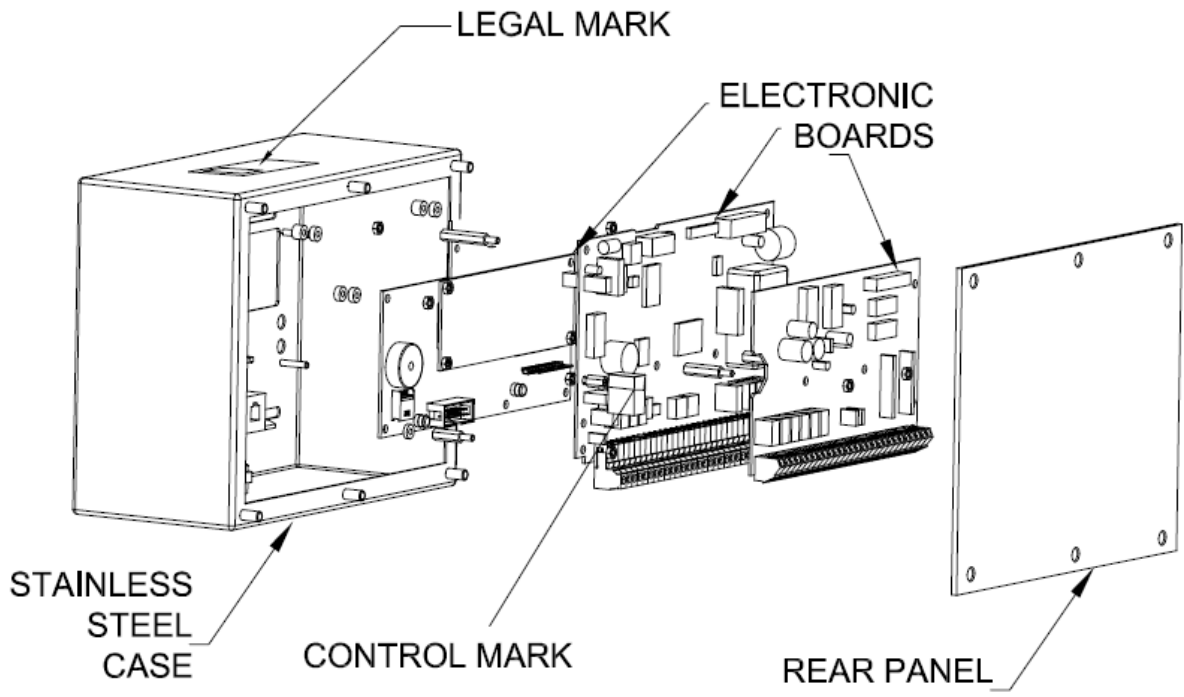

Figure 19 – CPWE series - Stainless steel case version

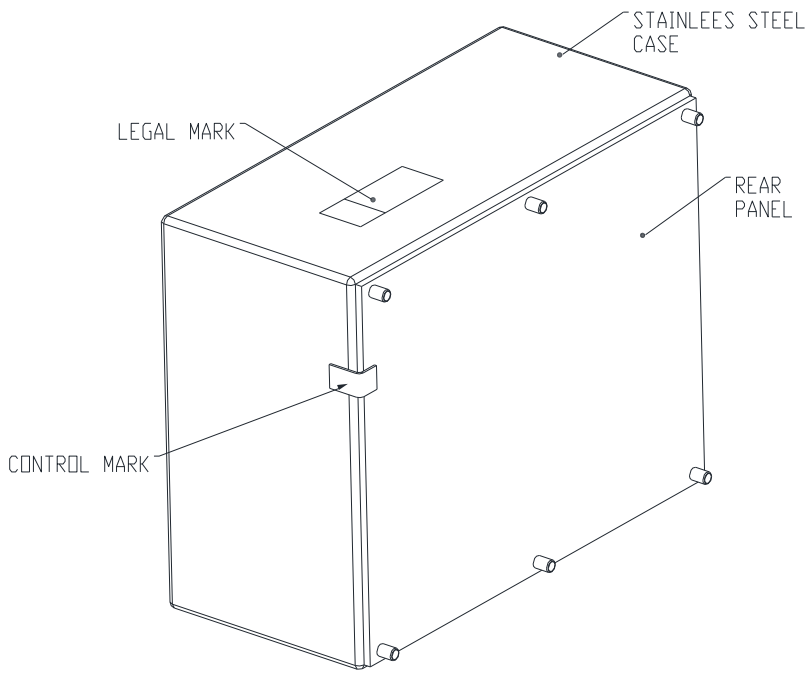

Figure 19a – CPWE series - Stainless steel case version alternative sealing method

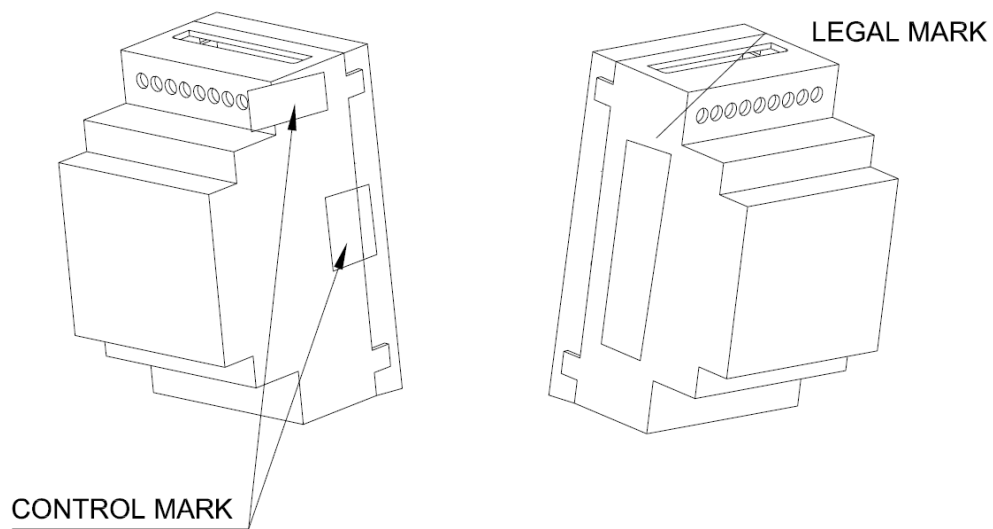

Figure 20 – DGT series - Plastic case version (example case 1)

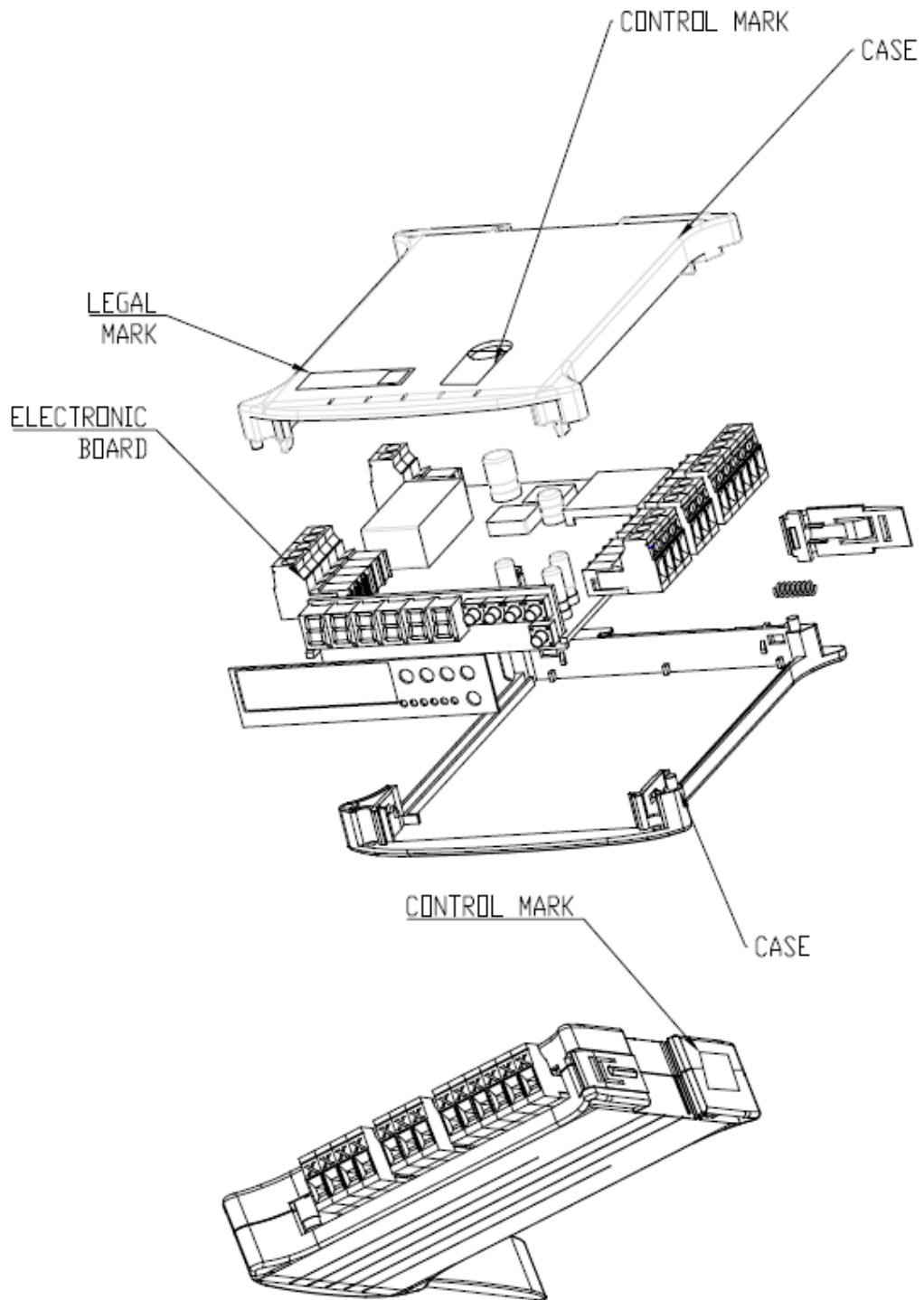

Figure 21 – DGT series - Plastic case version (example case 2)

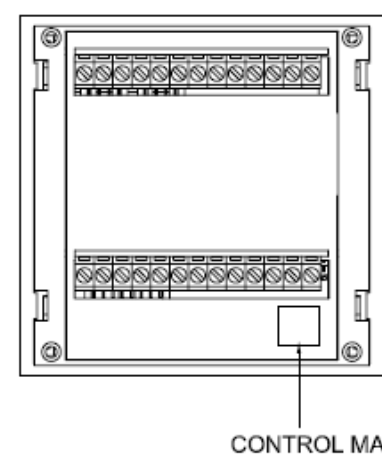
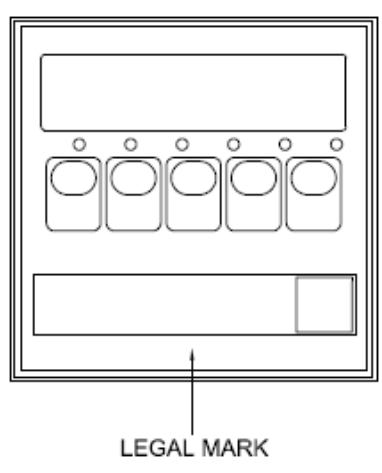
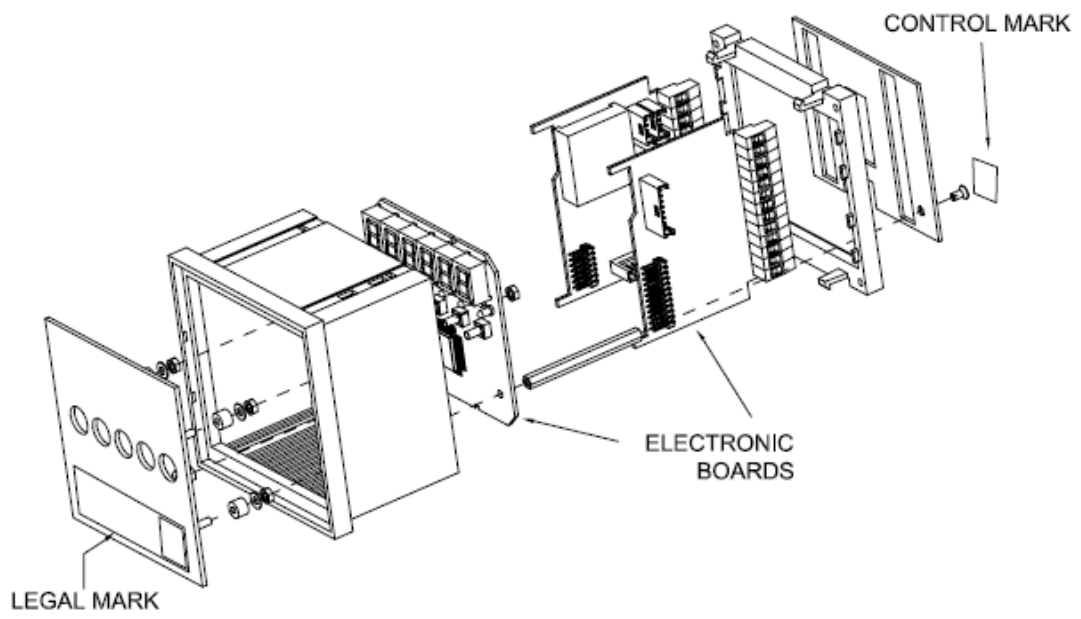

Figure 22 – DGT series - Plastic case version (example case 3)

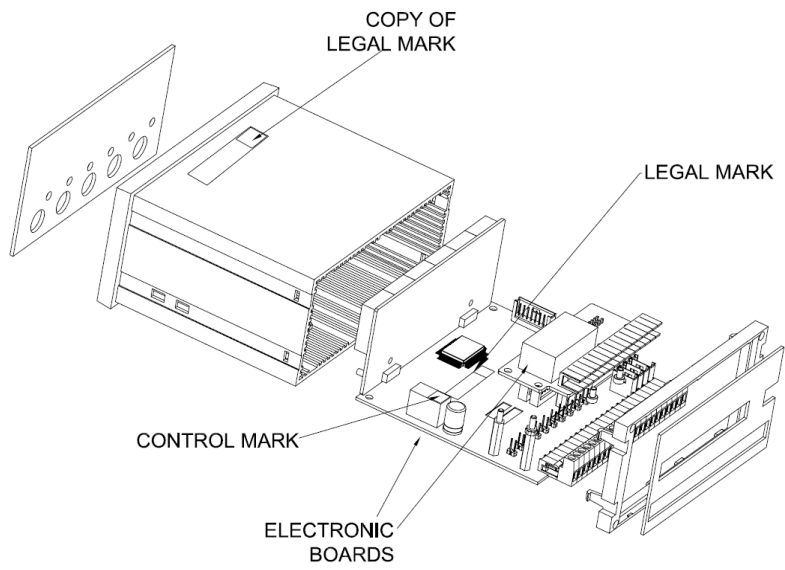

Figure 23 – DGT series - Plastic case version (example case 4)

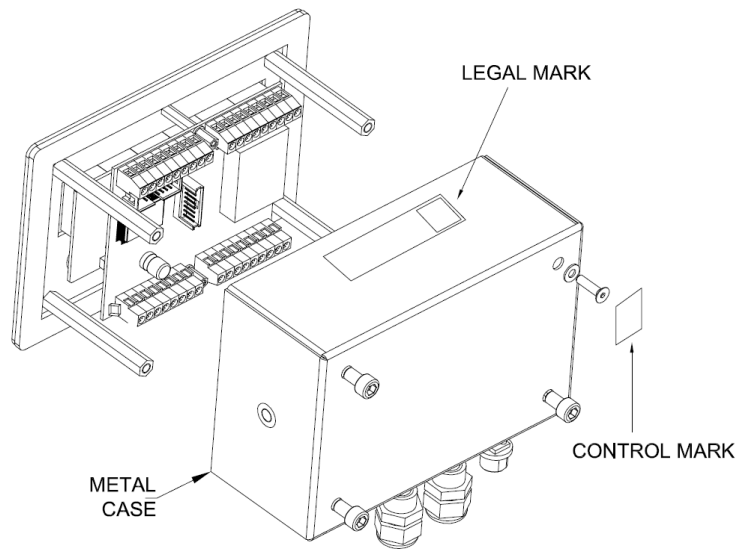

Figure 24 – DGT series – Metal case version (example case 1)

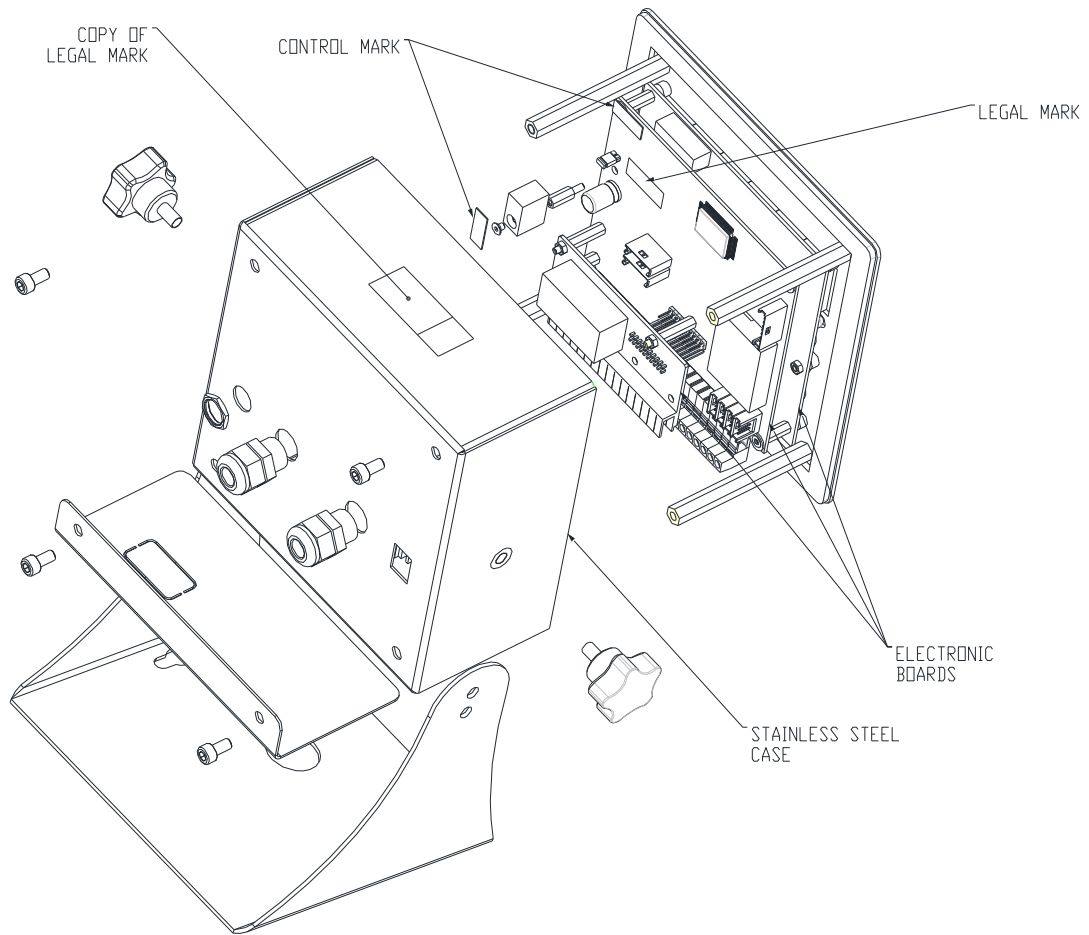

Figure 25 – DGT series – Metal case version (example case 2)

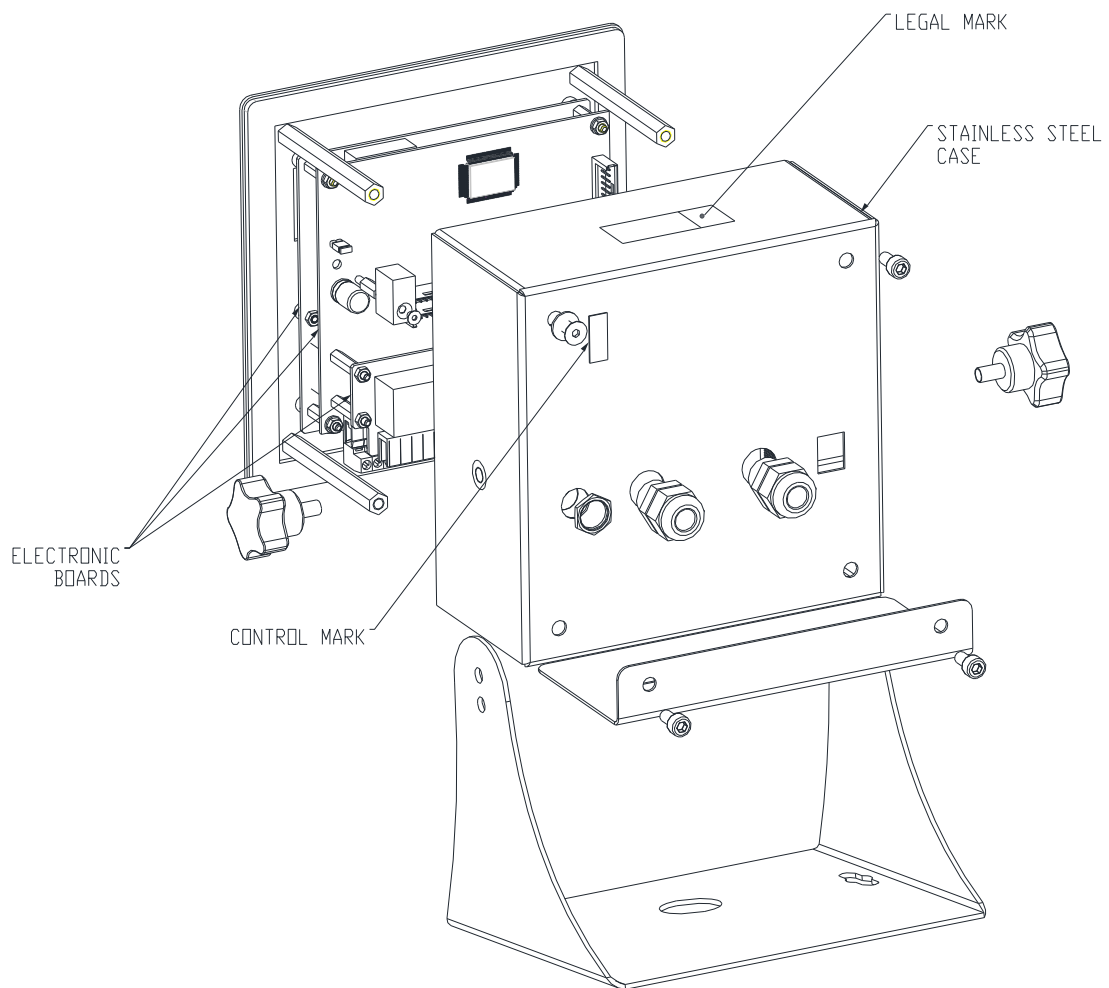

Figure 25a – DGT series – Metal case version (example case 2) alternative sealing method

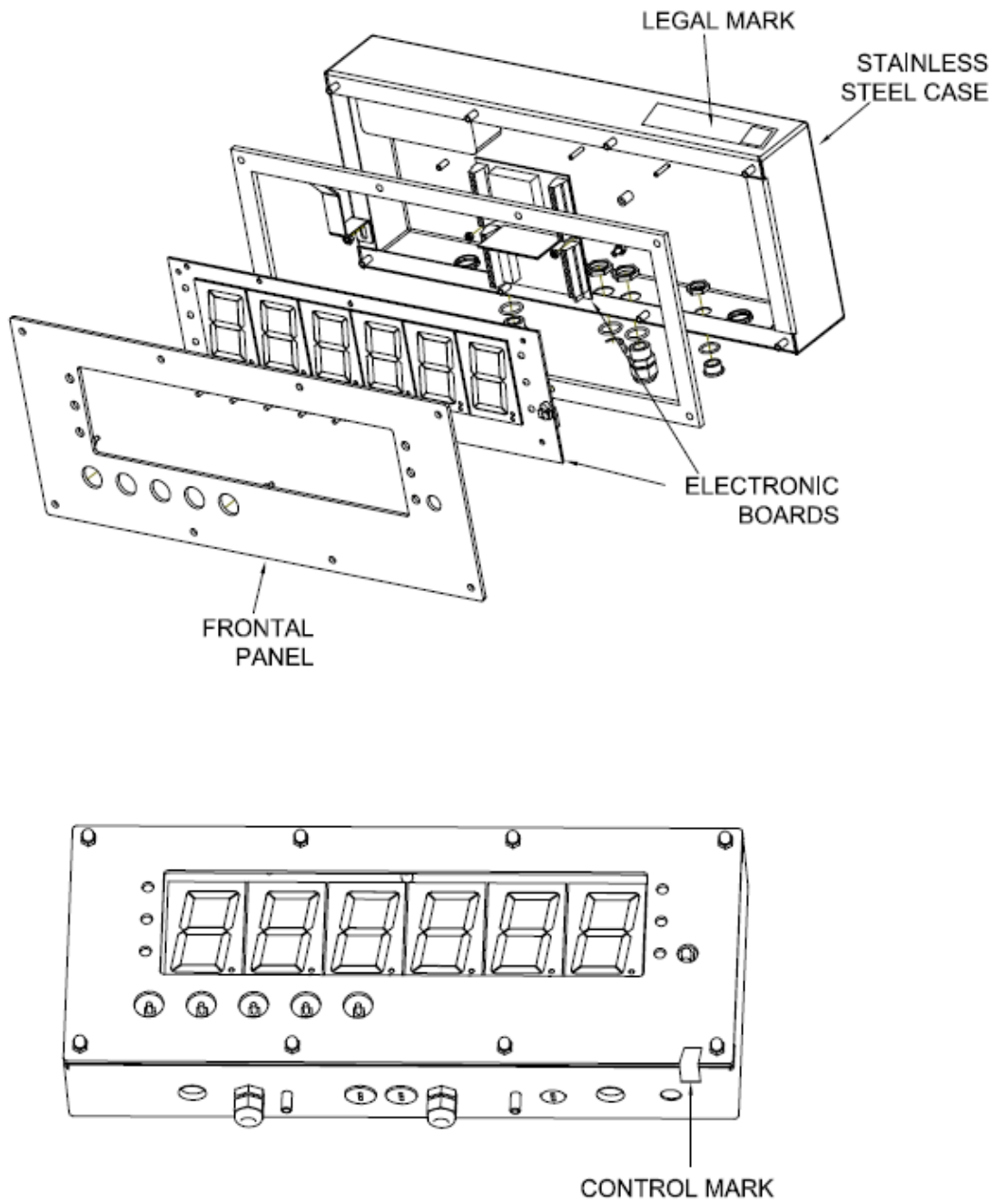

Figure 26 – DGT series - Stainless steel case version (example case 1)

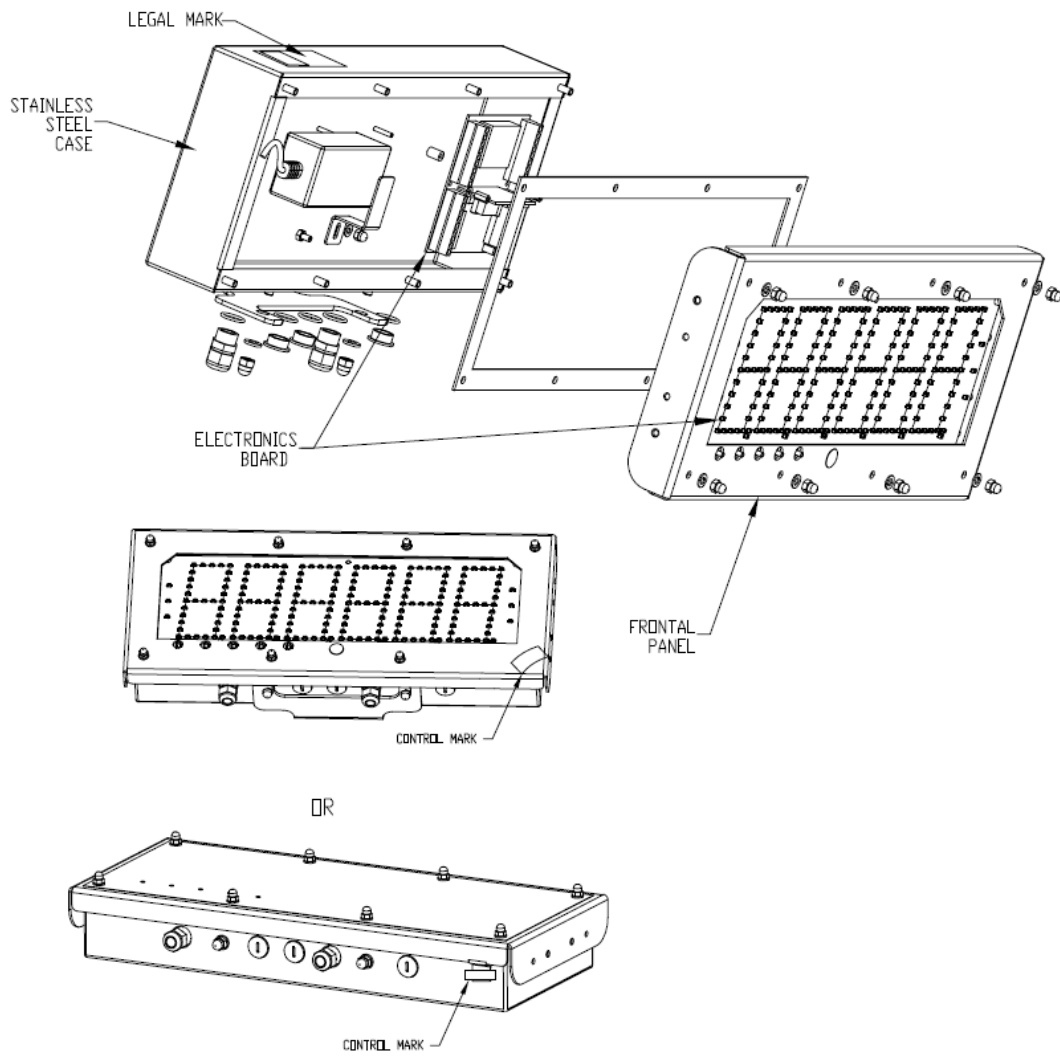
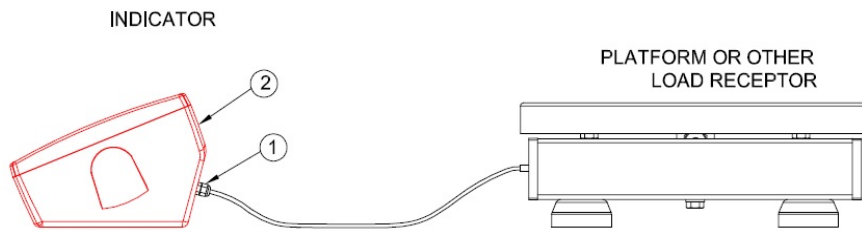

Figure 27 – DGT series - Stainless steel case version (example case 2)

A) CONSTRAINED CONNECTIONS



- ① CONNECTION WITH COSTRAINT
- ② LEGISLATION LABEL AND PROTECTION SEAL ON THE INDICATOR

B) UNCONSTRAINED CONNECTION

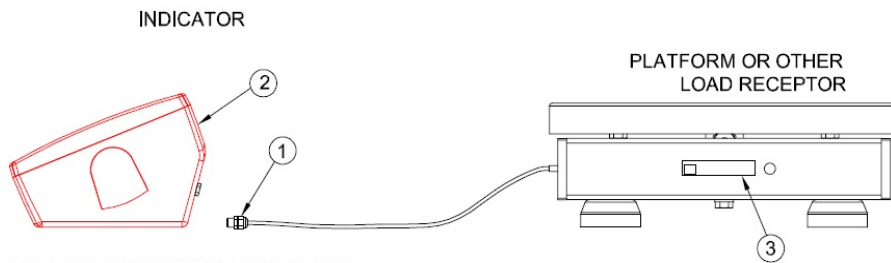

- ① CONNECTION WITHOUT COSTRAINT
- ② LEGISLATION LABEL AND PROTECTION SEAL ON THE INDICATOR
- ③ LABEL WITH IDENTIFYNG MARK IF THE LINKED INDICATOR
- ④ EVENTUAL CONSTRAINED JUNCTION OR DISTRIBUTION BOX

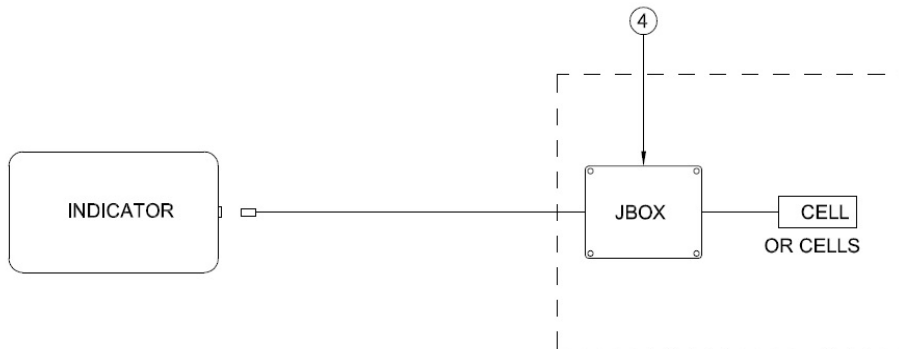

WITHOUT JBOX THE LOAD CELL WILL BE COSTRAINED TO LOAD RECEPTOR

Figure 28 – Examples of connections between indicators and load cells

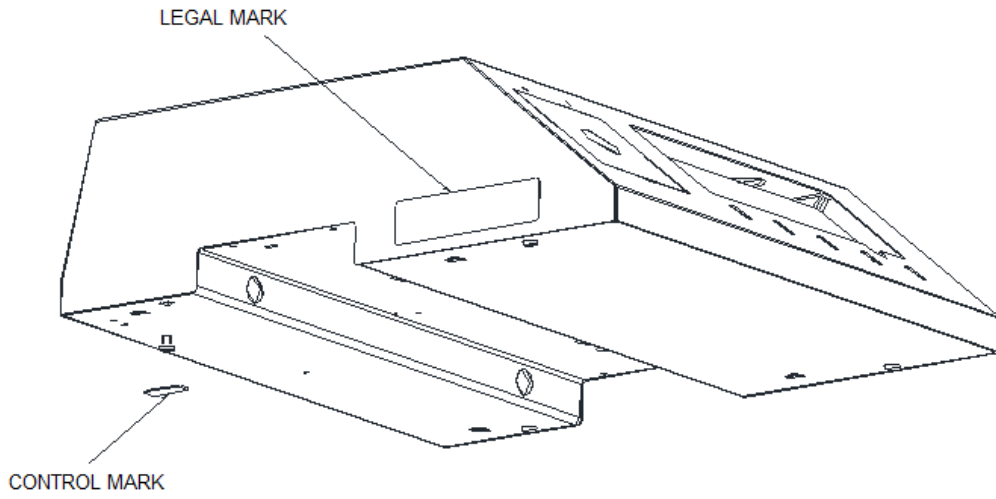

Alternative sealing method

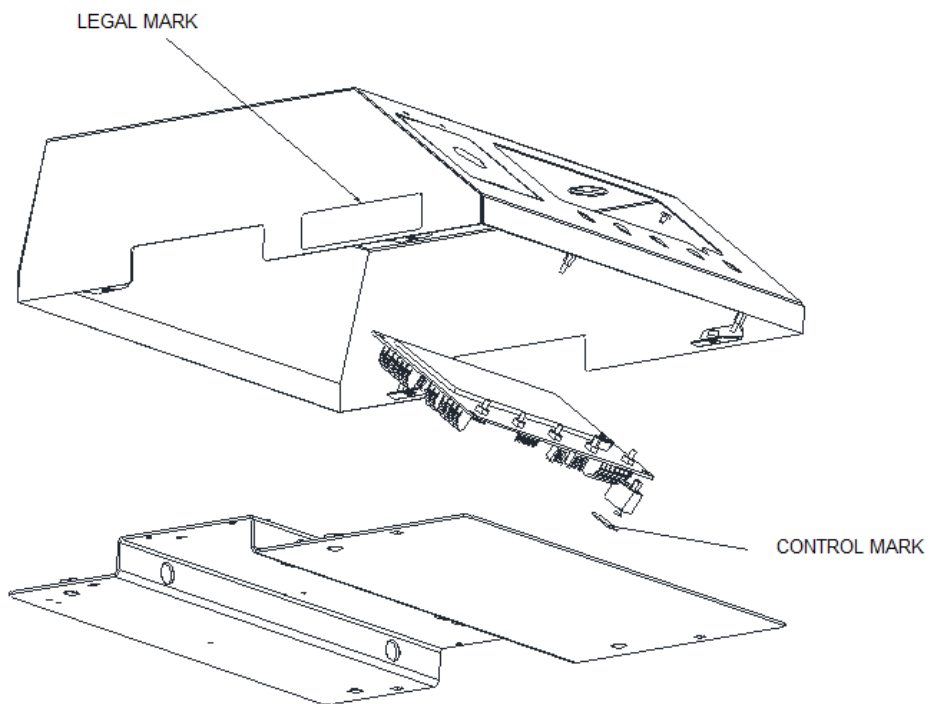

Figure 29 – KS series - Stainless steel case version

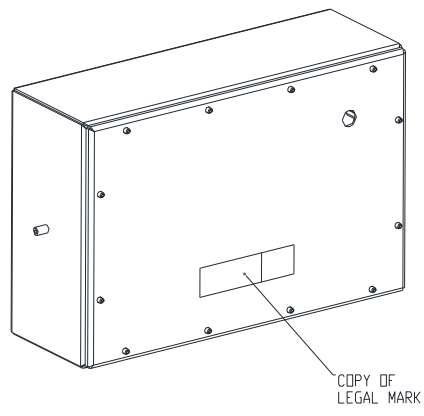
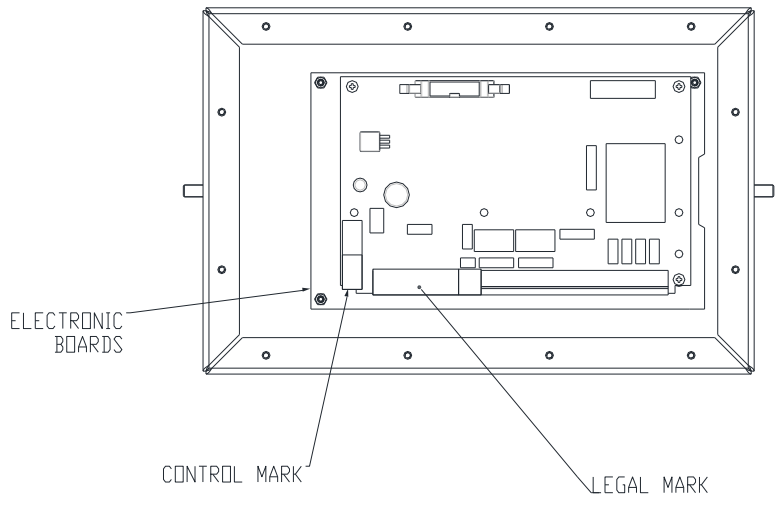
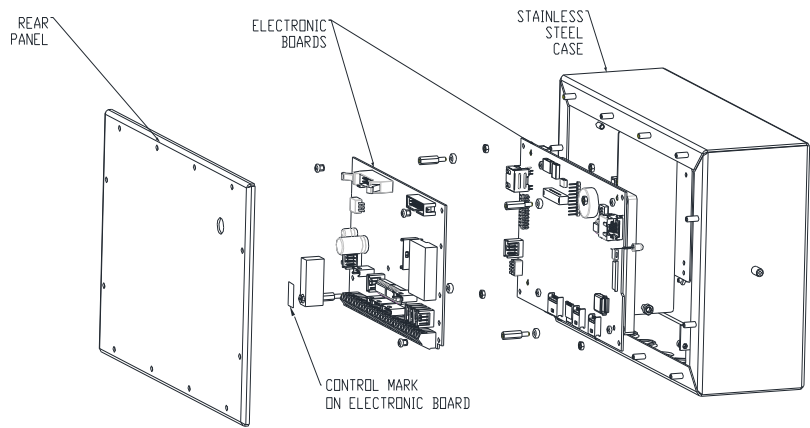

Figure 30 - 3590E Series – Stainless steel case and graphic touch (example case 4)

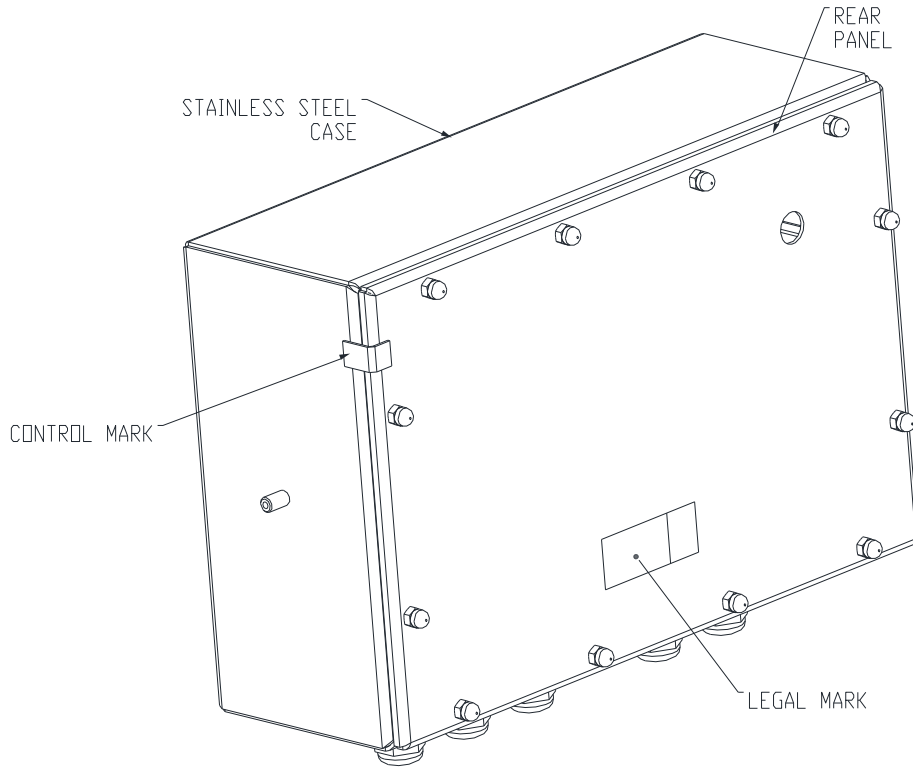

Figure 30a - 3590E Series – Stainless steel case and graphic touch (example case 4) alternative sealing method

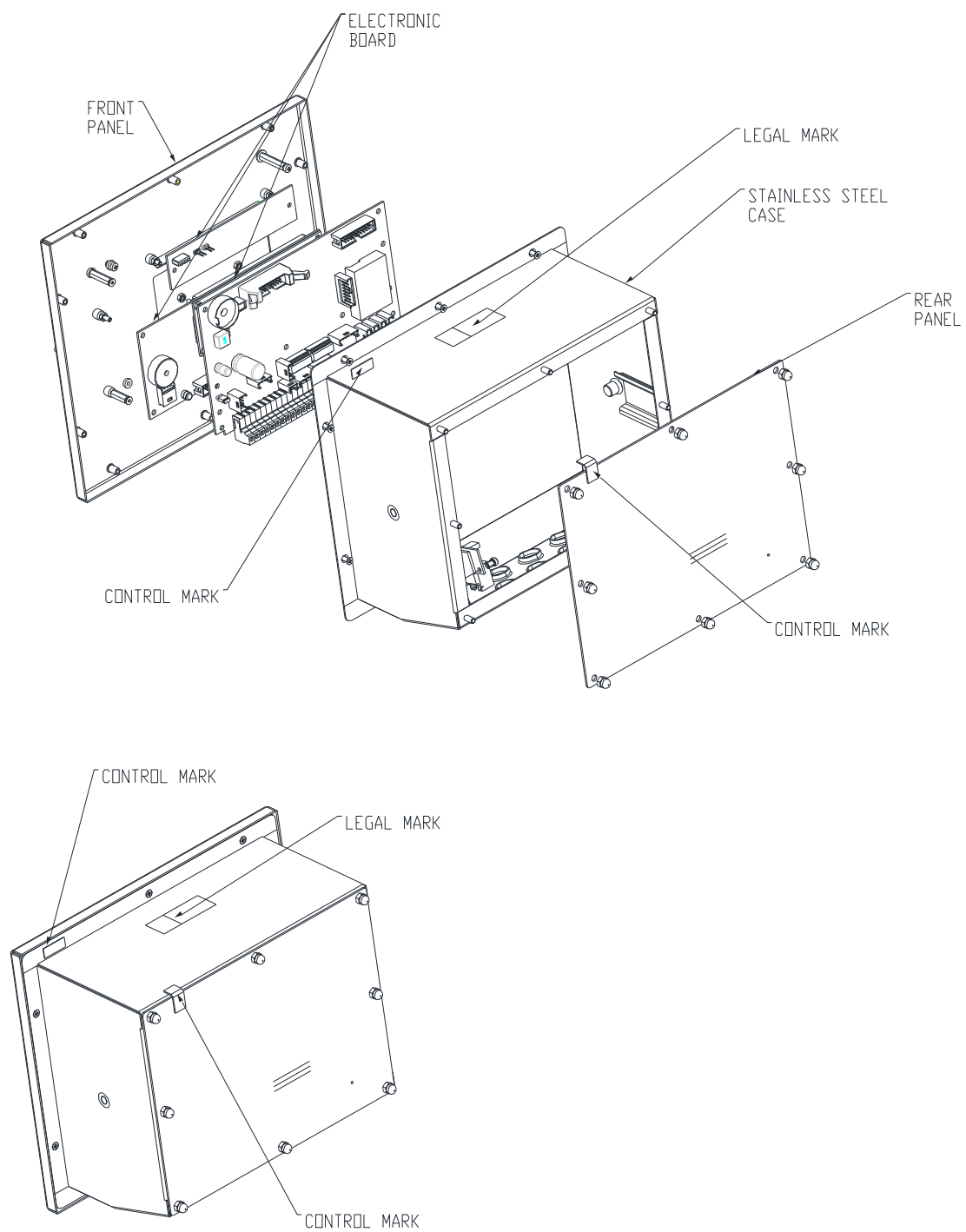

Figure 31 – CPWE Series – Stainless steel case (example case 2)

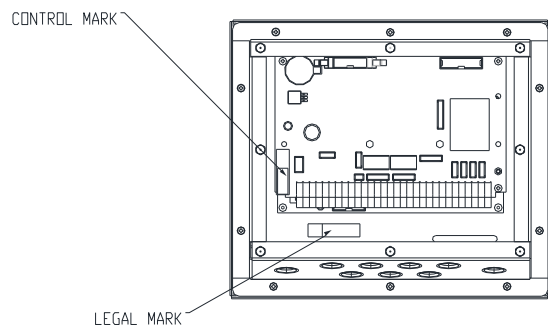
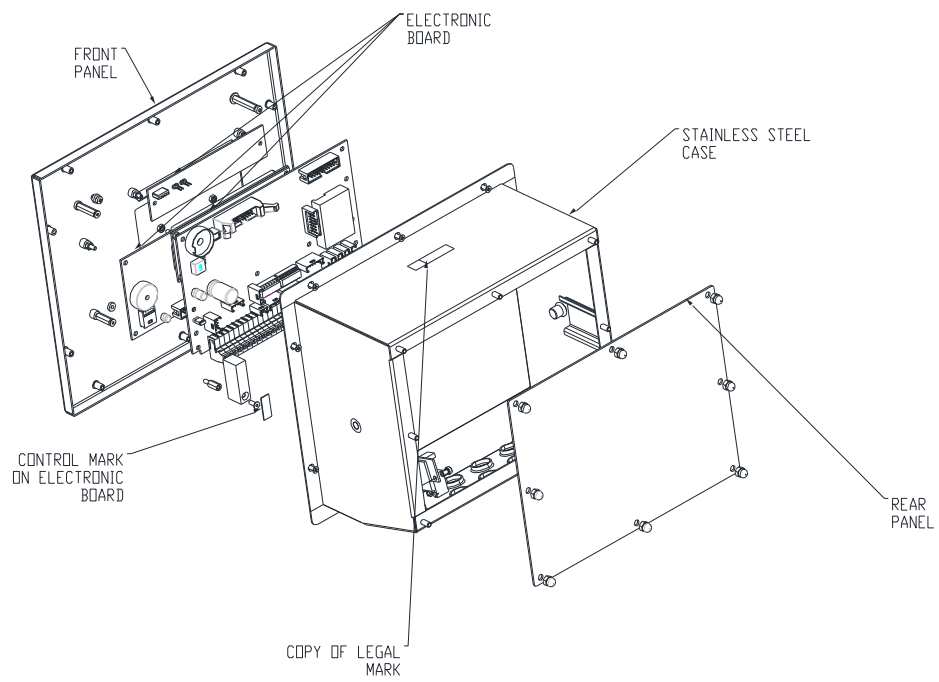

Figure 31a – CPWE Series – Stainless steel case (example case 2) alternative sealing method



Figure 32 - GLR100 secondary display (alternative 8.5)